



PARTS DRAWING



**Elite 240v 2.4kw
Quartz Halogen Heater**

**Product Code:
EH240MK3**

Serial Number Range:

From:

To:

Year Of Manufacture:



***Please note, when ordering online via our website if the part number is not recognised, please Email spares@hscgroupuk.co.uk or Telephone 0115 946 1988**

KEEP THIS BOOKLET FOR FUTURE REFERENCE

Nottingham: 0115 946 1988 • London: 0208 830 3333 ✉ Nottingham: sales@hscgroupuk.co.uk • London: sean@hscgroupuk.co.uk 🌐 www.hscgroupuk.co.uk

The Hire Supply Company Terms & Conditions Apply At All Time E&OE

Elite Heat MK3 Spare Parts List

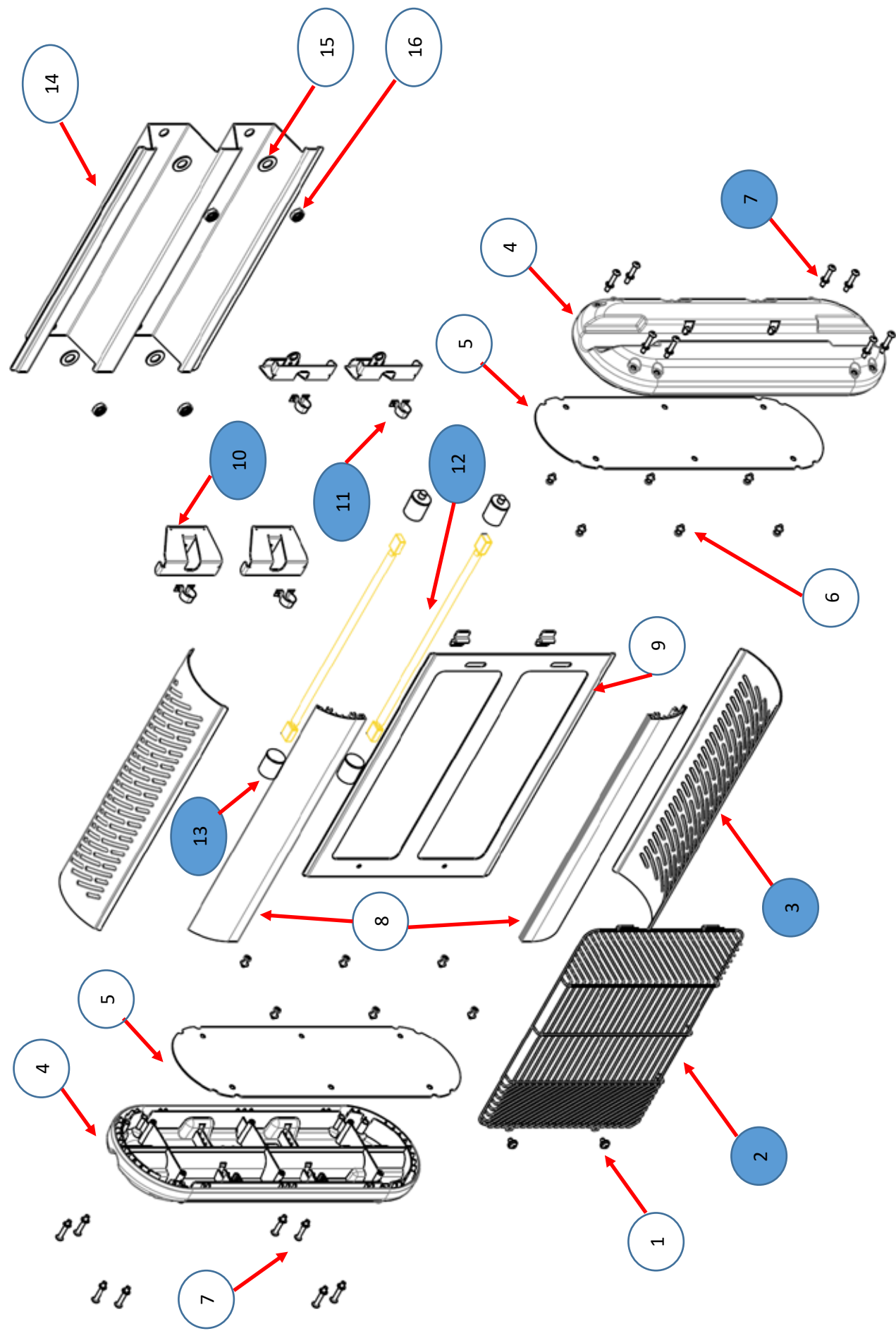

Elite Heat MK3 Spare Parts List

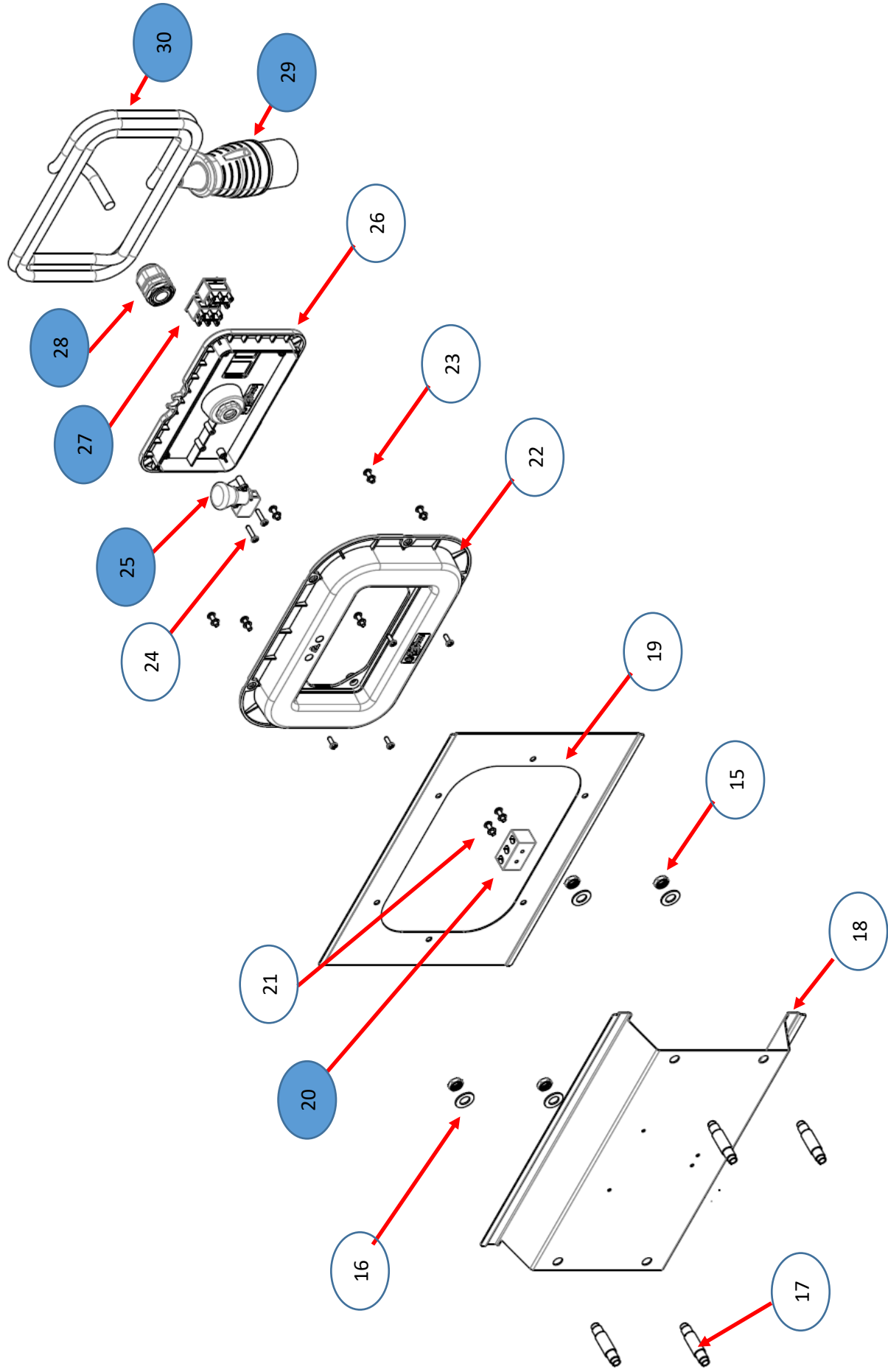

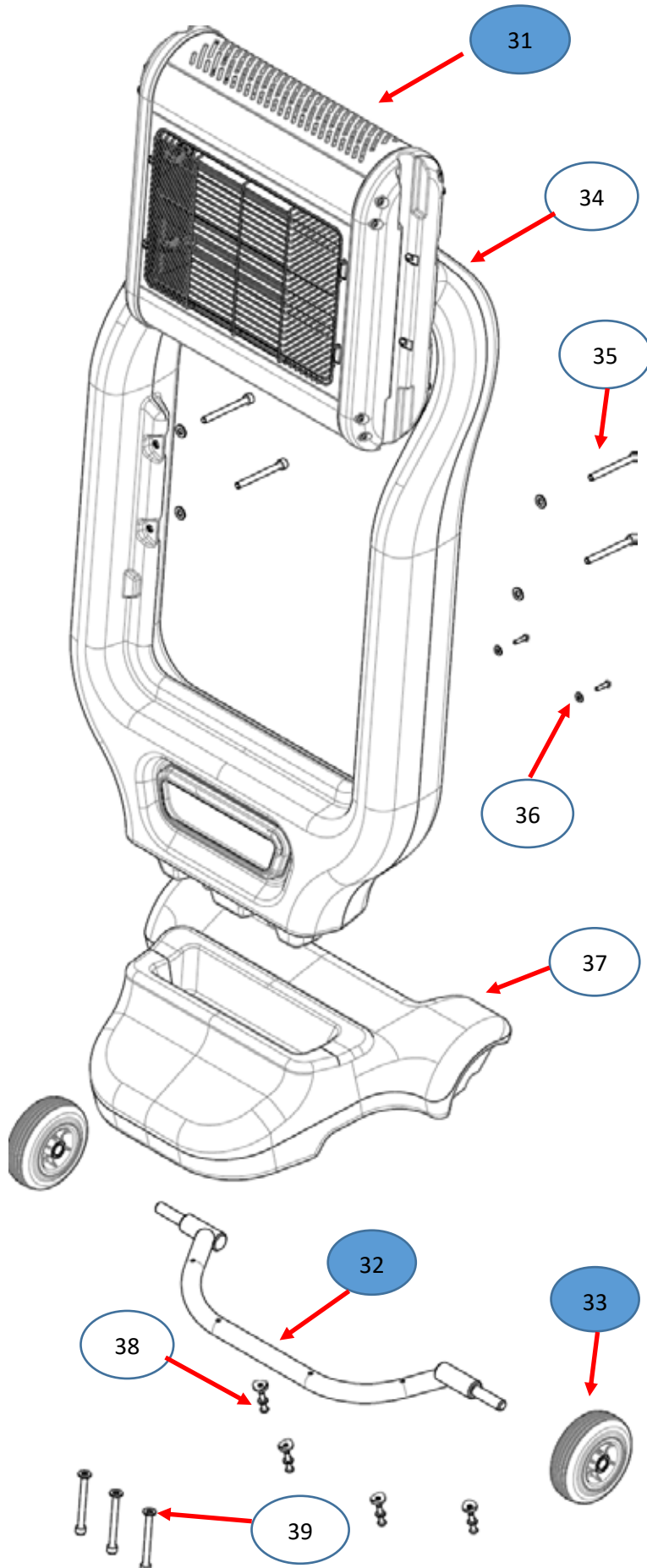

No.	PN. No.	Description	Availability
1	N/A	Front Safety grille retaining screw - M4 x 12mm Pozi button head screw incl flange	Call for availability
2	EHMK3-005	BZP safety guard	Stock Item
3	EHMK3-014	Vented grill - top and bottom	Stock Item
4	N/A	Cassette Side Moulding	Call for availability
5	N/A	Cassette Side Moulding - reflector panel	Call for availability
6	N/A	Cassette Side Moulding - reflector panel Fixing screws - 5.0 x 12mm self tapping screw incl washer	Call for availability
7	N/A	Cassette Side Moulding - reflector panel Fixing screws - M5 x 30mm self tapping screw	Call for availability
8	N/A	Cassette Aluminium extrusion profile	Call for availability
9	N/A	Cassette Front Panel	Call for availability
10	EHMK3-016	Lamp Bracket	Stock Item
11	EHMK3-015	Lamp Clip	Stock Item
12	EHMK3-007	110V Tube - SK15	Stock Item
12	EHMK3-008	240V Tube - SK15	Stock Item
13	EHMK3-006	Ceramic Lamp End Caps	Stock Item
14	N/A	Cassette Lamp Reflector Panel	Call for availability
15	N/A	Infra Red Tube cable boss - M12 Nut Fixing Nut	Call for availability
16	N/A	Infra Red Tube cable boss - M12 Washer	Call for availability
17	N/A	Infra Red Tube cable boss	Call for availability
18	N/A	Cassette Control panel fixing plate	Call for availability
19	N/A	Cassette rear panel	Call for availability
20	EHMK3-003	Lamp terminal block	Stock Item
21	N/A	Lamp terminal block - Fixing screws M4x 12mm screw	Call for availability



Elite Heat MK3 Spare Parts List

No.	PN. No.	Description	Availability
22	N/A	Rear moulded cable storage	Call for availability
23	N/A	Rear moulded cable storage - Fixing screws M4 x 30 mm Socket Button Head Machine Screw	Call for availability
24	N/A	Safety tilt microswitch - Fixing screws M4 x 12mm Pan Pozi Button Head Machine Screw	Call for availability
25	EHMK3-004	Safety tilt microswitch	Stock Item
26	N/A	Moulded Control Panel cover	Call for availability
27	EHMK3-001	ON / OFF rocker switch	Stock Item
28	EHMK3-012	Cable Gland 110V M20	Stock Item
28	EHMK3-013	Cable Gland 240V M16	Stock Item
29	P32AP110	110V 32A Plug	Stock Item
29	13APR.	240V 13A Plug	Stock Item
30	N/A	110V 4.0mm H05 VVF cable @ 2M	Call for availability
30	H071.53C	240V 1.5mm H07 RNF cable @ 3M	Stock Item
31	EHMK3-009	110V Complete Heater Cassette	Stock Item
31	EHMK3-010	240V Complete Heater Cassette	Stock Item
32	EHMK3-011	Wheel Axle	Stock Item
33	EHMK3-002	Wheel	Stock Item
34	EHMK3-034	Main Body	Stock Item
35	N/A	Heater Cassette Fixings - M8 x 110mm Skt Cap Head (X4) M8 Washer	Call for availability
36	N/A	Brand Plate Fixing Screws - 4.0 x 16mm self tapper (X2)	Call for availability
37	EHMK3BA	Base wheel axle assembly	Stock Item
38	N/A	Axle fixing bolt - M8 x 35mm Skt Cap Head (X4) incl washer and spring washer	Call for availability
39	N/A	Base fixing bolt - M10 x 40mm Skt Cap Head (X4) incl washer and spring washer	Call for availability



Recycling



ENVIRONMENTAL PROTECTION: Please recycle any unwanted materials as opposed to disposing them as general waste. It is recommended the original is retained and used to store the product when not in use for prolonged periods of time. If this is not applicable ensure the materials are sorted and recycled in accordance with local regulations.



SPECIFICATION CHANGE: It is our policy to continually improve products to ensure these meet the rigours of the industry we serve. Therefore, as such we reserve the right to alter specifications, data, components & parts with-out prior notice.

WARRANTY: Please refer to the manufactures terms & conditions.

IMPORTANT: No liability will be accepted for the incorrect use of this product.

KEEP THIS BOOKLET FOR FUTURE REFERENCE

📞 Nottingham: 0115 946 1988 • London: 0208 830 3333 ✉ Nottingham: sales@hscgroupuk.co.uk • London: sean@hscgroupuk.co.uk 🌐 www.hscgroupuk.co.uk

The Hire Supply Company Terms & Conditions Apply At All Time E&OE