



USER MANUAL

MCE MASTER
CLIMATE SOLUTIONS

**Master Dual Voltage
45.9ltr De Humidifier**

**Product Code:
DHP55DV**

Serial Number Range:

From:

To:

Year Of Manufacture: 2021



***Please note, when ordering online via our website if the part number is not recognised, please Email spares@hscgroupuk.co.uk or Telephone 0115 946 1988**

KEEP THIS BOOKLET FOR FUTURE REFERENCE

Nottingham: 0115 946 1988 • London: 0208 830 3333 ✉ Nottingham: sales@hscgroupuk.co.uk • London: sean@hscgroupuk.co.uk 🌐 www.hscgroupuk.co.uk

The Hire Supply Company Terms & Conditions Apply At All Time E&OE



MAS CLIMATE SOLUTIONS



Dantherm S.p.A.

Via Gardesana 11, 37010-
Pastrengo (VR), Italy

Dantherm Sp. z o.o.

ul. Magazyńowa 5A,
62-023 Gądki, Poland

Dantherm LLC

ul. Transportnaya 22/2,
142802, STUPINO, Moscow region, Russia

Dantherm China LTD

Unit 2B, 512 Yunchuan Rd.,
Shanghai, 201906, China

Dantherm SP S.A.

C/Calabozos, 6 Poligono Industrial, 28108
Alcobendas (Madrid) Spain

Dantherm S.p.A.

Via Gardesana 11, 37010
Pastrengo (Verona), Italia

Dantherm Sp. z o.o.

ul. Magazyńowa 5A,
62-023 Gądki, Polska

ООО «Дантерм»

Ул. Транспортная, 22/2,
142802, г. Ступино, Московская обл., РФ

Dantherm China LTD

Юньчуань роад, 512, строение 2B,
Шанхай, 201906, Китай

Dantherm SP S.A.

Ц/Калобозос, 6 Полигоно Индустриал,
28108 Алкобендас (Мадрид) Испания

en

it

de

es

fr

nl

da

pl

ru

cs

hu

lt

lv

et

ro

uk

zh

USER AND MAINTENANCE BOOK

LIBRETTO USO E MANUTENZIONE

BEDIENUNGS- UND WARTUNGSANLEITUNG

MANUAL DE INSTRUCCIONES PARA EL USO Y MANTENIMIENTO

MANUEL D'UTILISATION ET DE MAINTENANCE

HANDLEIDING VOOR GEBRUIK EN ONDERHOUD

VEJLEDNING OM BRUG OG VEDLIGEHOLDELSE

INSTRUKCJA OBSŁUGI I KONSERWACJI

РУКОВОДСТВО ПО ЭКСПЛУАТАЦИИ И ТЕХНИЧЕСКОМУ ОБСЛУЖИВАНИЮ

PŘÍRUČKA PRO POUŽITÍ A ÚDRŽBU

HASZNÁLATI ÉS KARBANTARTÁSI KÉZIKÖNYV

NAUDOJIMO IR PRIEŽIŪROS KNYGELE

LIETOŠANAS UN TEHNISKĀS APKOPES GRĀMATĪNA

KASUTUS - JA HOOLDUSJUHEND







LIVRET DE UTILIZARE SI ÎNTREȚINERE

ІНСТРУКЦІЯ З ОБСЛУГОВУВАННЯ

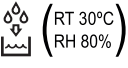
使用和维护手册

DHP 55 - DHP 55DV

**ТЕХНИЧЕСКИ ДАНИ - TECHNICKÉ ÚDAJE - TECHNISCHE DATEN - TEKNISK DATA -
 TEHNILISED ANDMED - ESPECIFICACIONES TÉCNICAS - TEKNISET TIEDOT -
 DONNÉES TECHNIQUES - TECHNICAL DATA - TEHNIČKI PODACI - MŐSZAKI ADATOK -
 DATI TECNICI - TECHNINIAI DUOMENYS - TEHNISKIE DATI - TECHNISCHE GEGEVENS
 - TEKNISKE DATA - DANE TECHNICZNE - DADOS TÉCNICOS - INFORMAII TEHNICE -
 ТЕХНИЧЕСКИЕ ДАННЫЕ - TEKNISKA DATA - TEHNIČNI PODATKI -
 TECHNICKÉ PARAMETRE - ТЕХНІЧНІ ДАНІ**

MODEL	DHP 55	DHP 55DV
	~220-240 V-B 50 Hz-Гц 790 W-Вт 4,2 A	~220-240 V-B 50 Hz-Гц 790 W-Вт 4,2 A ~110-120 V-B 50 Hz-Гц 810 W-Вт 8,4 A
 (RT 30°C RH 80%)	45,9 l/24h-л/24ч	45,9 l/24h-л/24ч
	340 m ³ /h-м ³ /ч	340 m ³ /h-м ³ /ч
	R290 0,15 kg-кг	R290 0,15 kg-кг
	5÷35°C	5÷35°C
	20÷90%	20÷90%
	≤52 dB-дБ	≤52 dB-дБ
	47 kg-кг	58 kg-кг
CO ₂ Eq	0,0005	0,0005
GWP	3	3

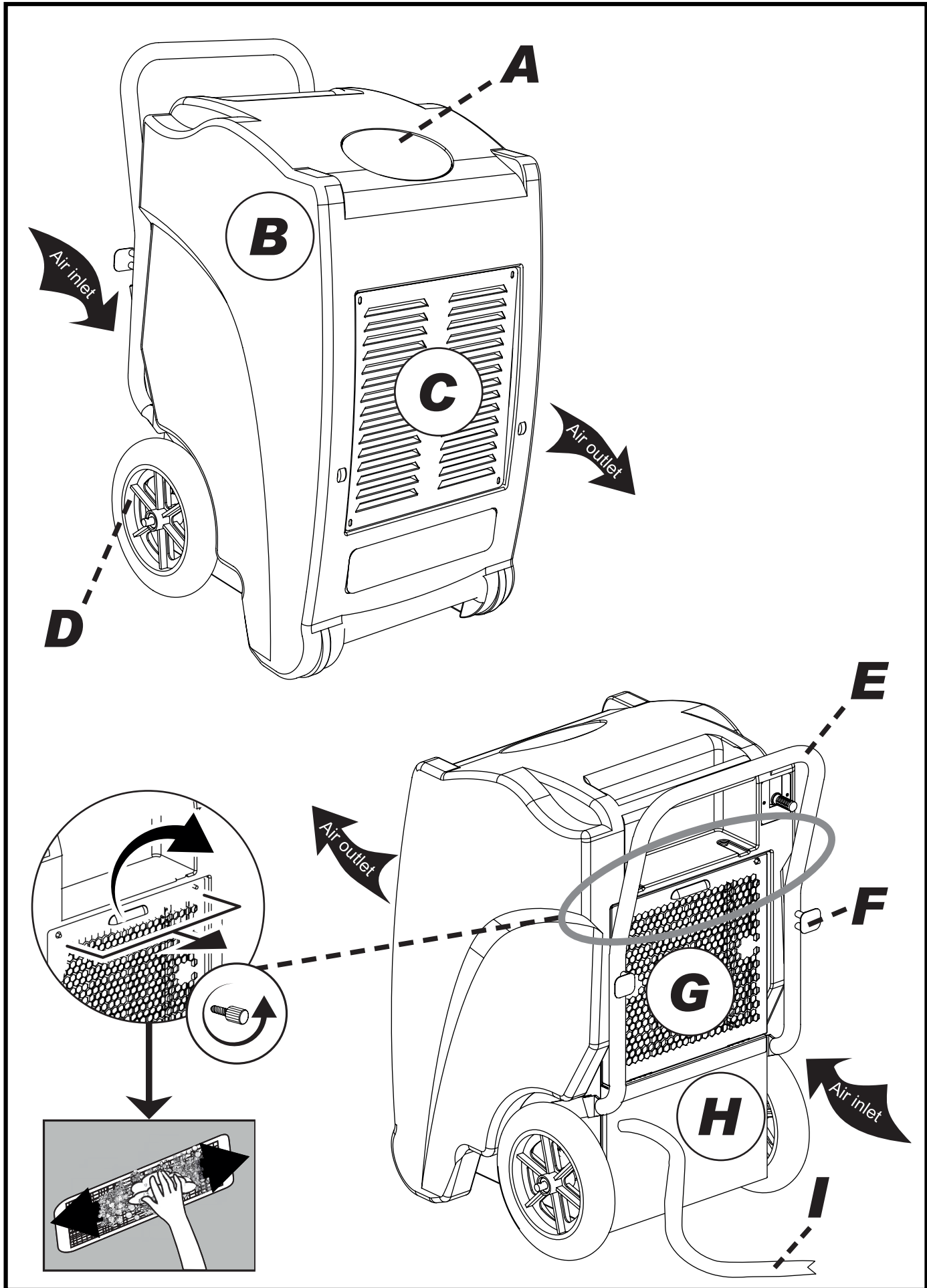

Fig. 1

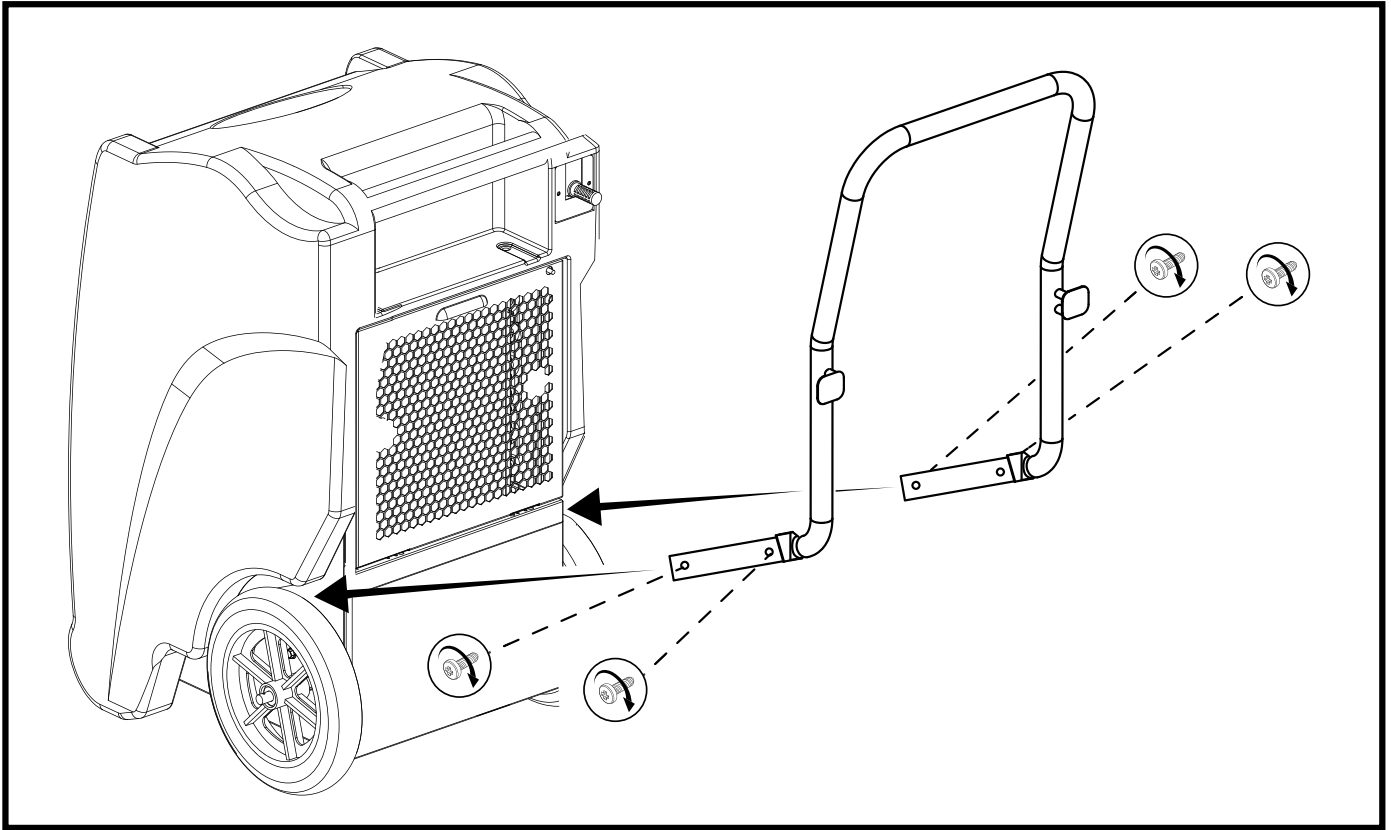

Fig. 1

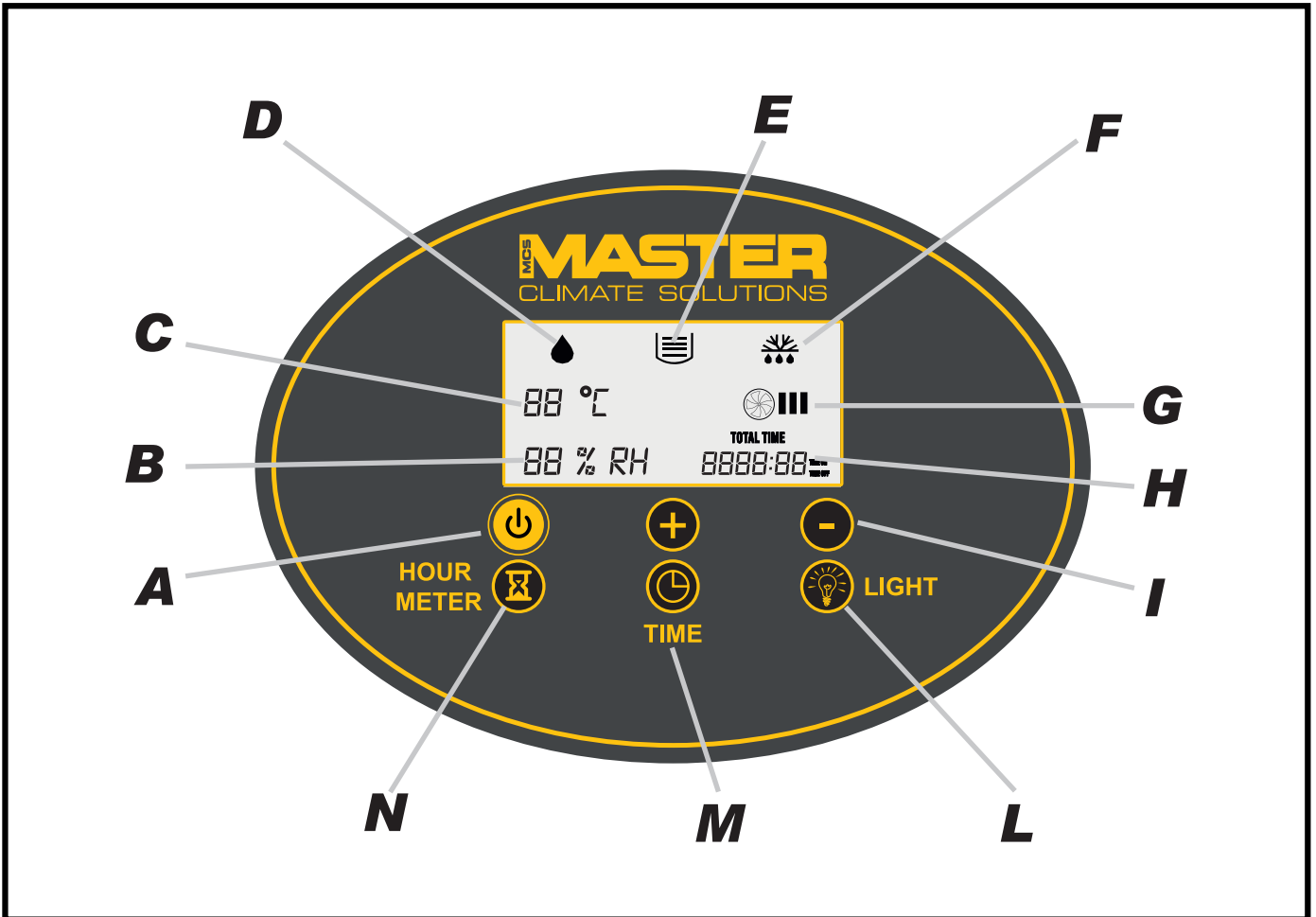

Fig. 2

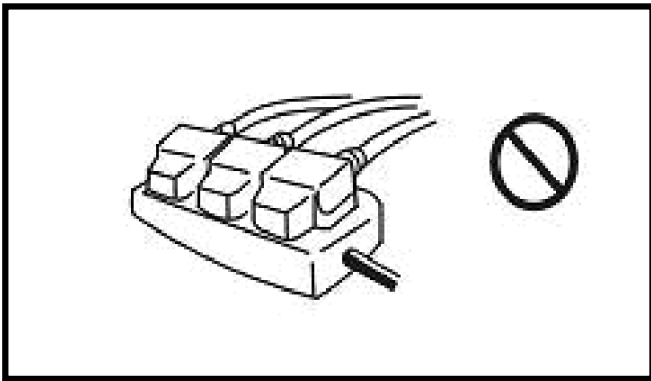

Fig. 3

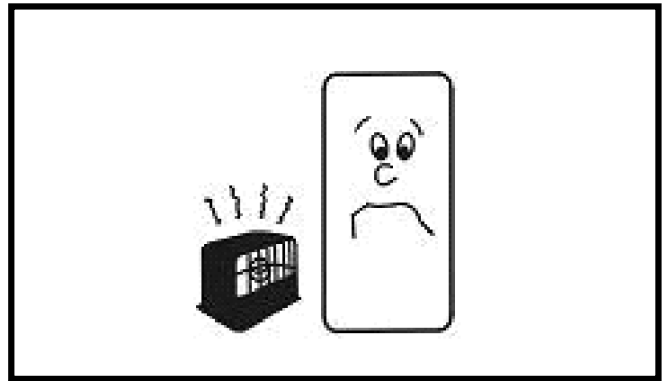

Fig. 4

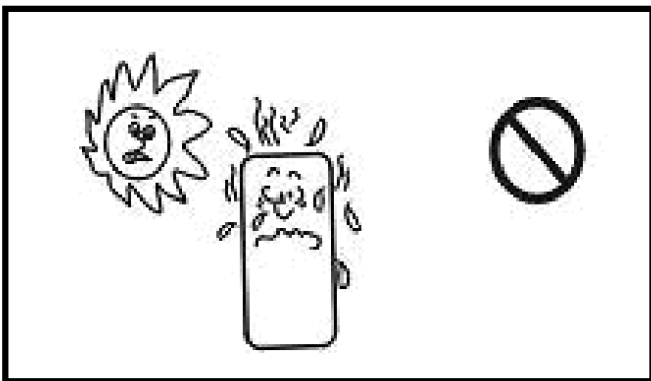

Fig. 5

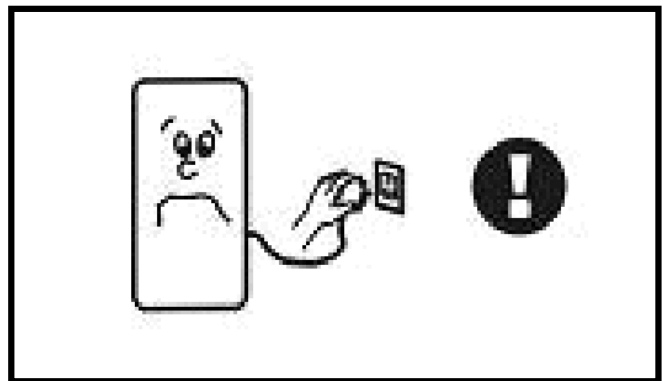

Fig. 6

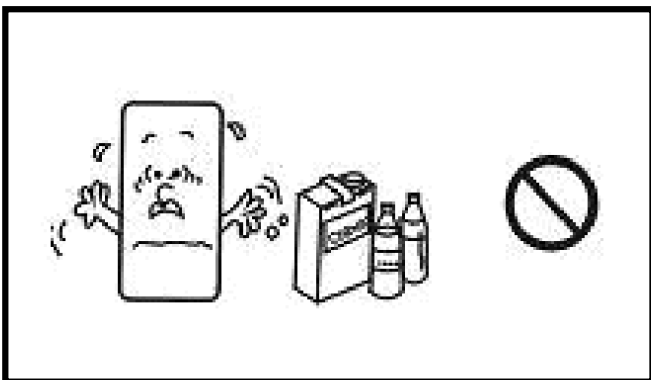

Fig. 7

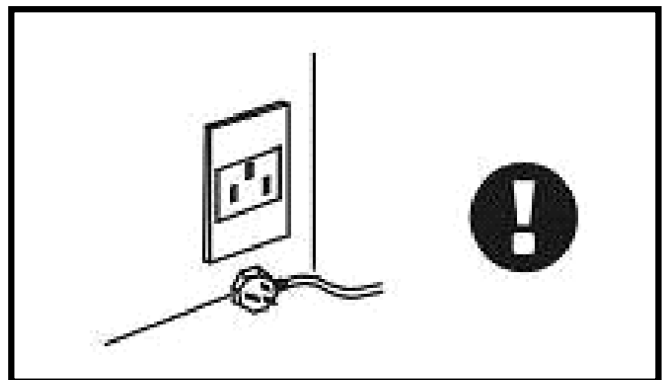

Fig. 8

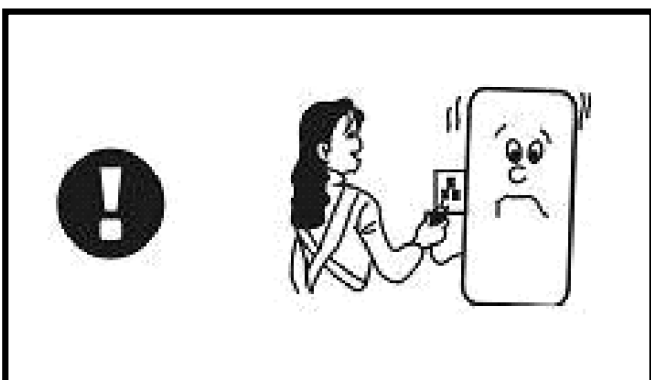

Fig. 9

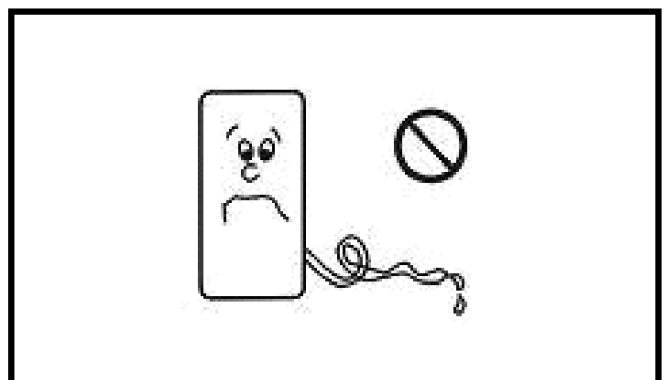

Fig. 10

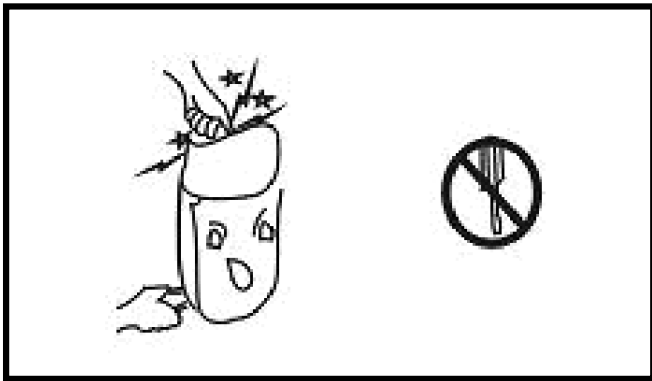

Fig. 11

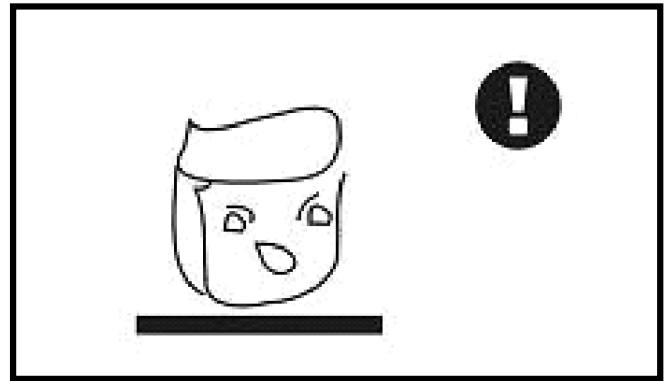

Fig. 12

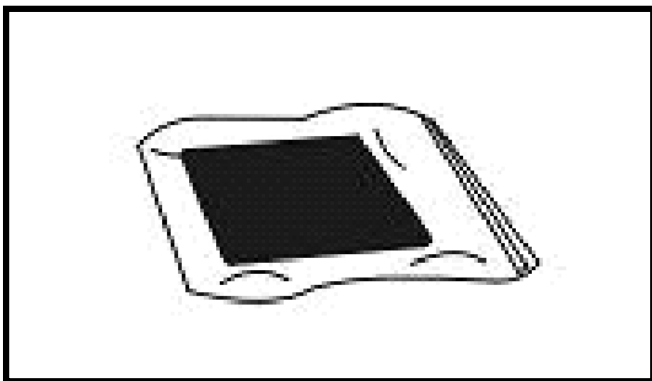

Fig. 13

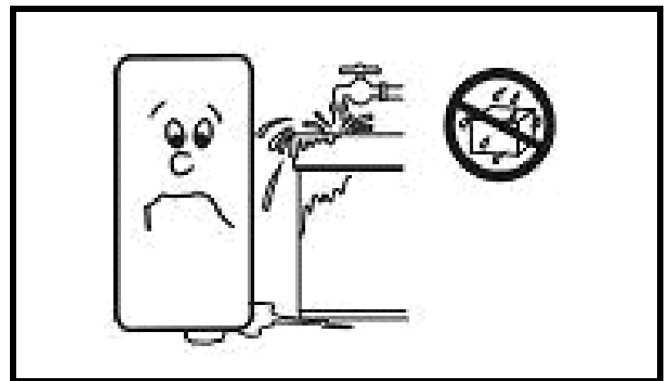

Fig. 14

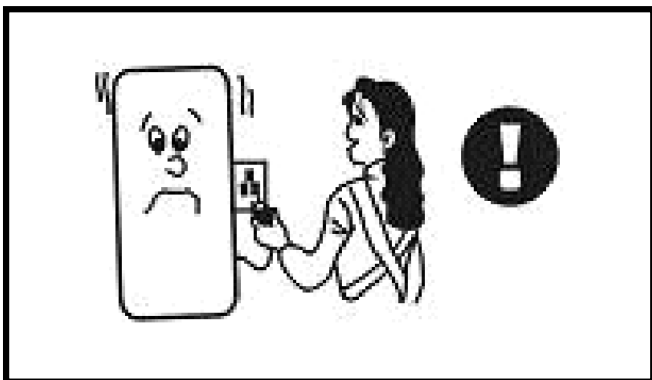

Fig. 15

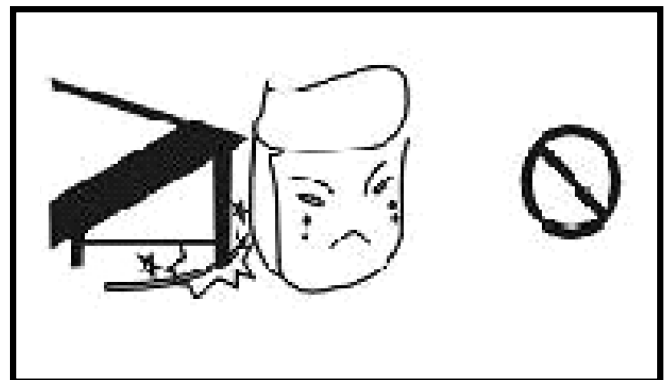

Fig. 16

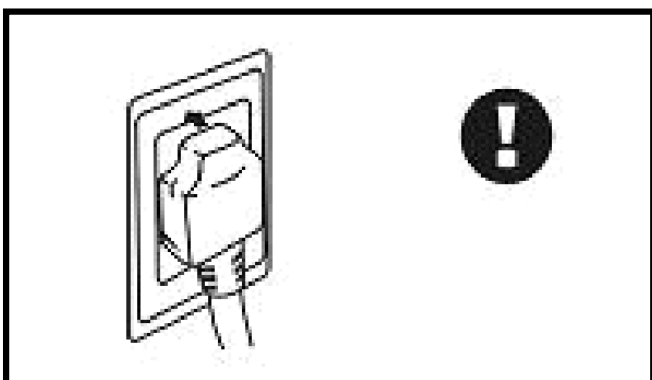

Fig. 17

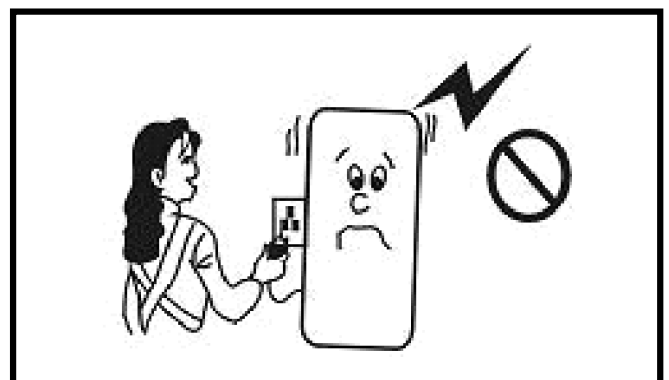

Fig. 18

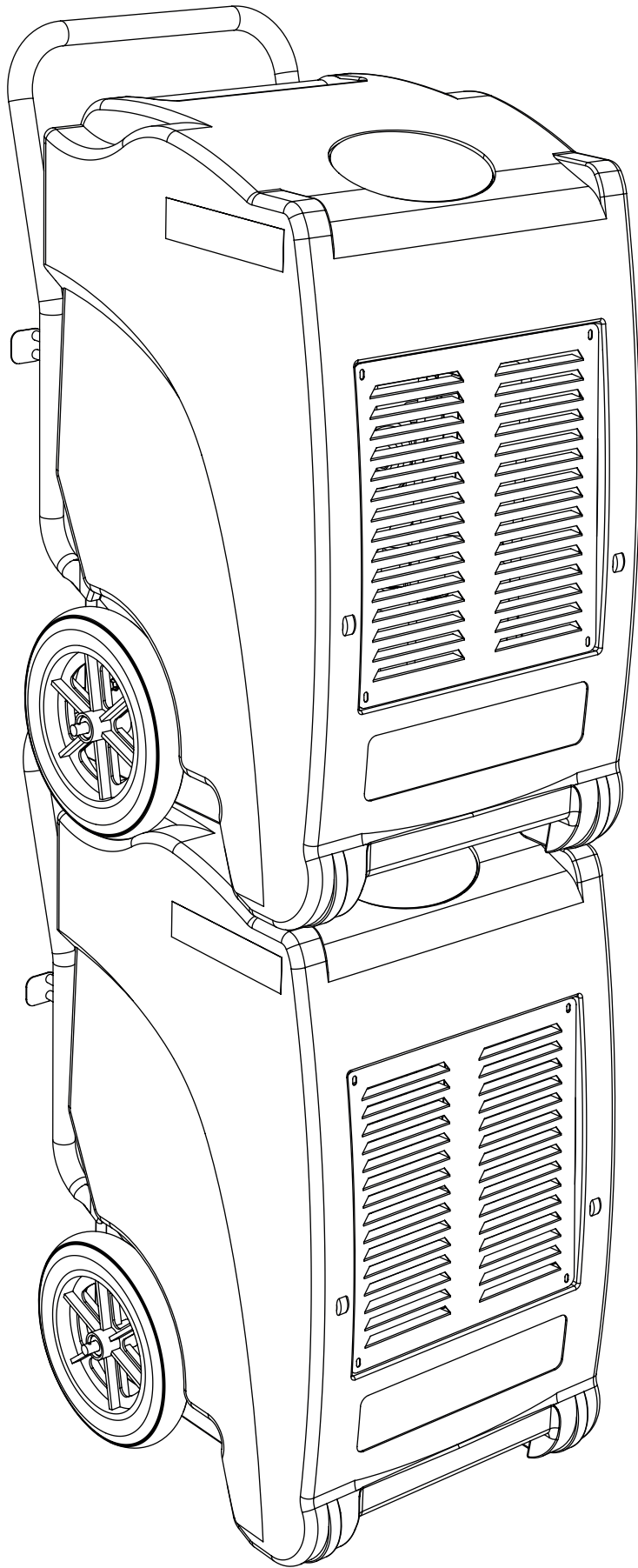

Fig. 19

1...	BEFORE USE
2...	CONSTRUCTION
3...	OPERATION
4...	MAINTENANCE AND SAFETY
5...	NOTICES ABOUT UNIT OPERATION
6...	ELIMINATION DE DÉTÉRIORATIONS

PLEASE TAKE TIME TO READ THIS MANUAL CAREFULLY BEFORE USE AND SAVE IT FOR FUTURE REFERENCE.

**►► 1. BEFORE USE
CAUTION!**



These symbols on your device mean:

- This appliance is filled with Propane gas R290. Follow strictly the manufacturer's instruction concerning use and repairs!
- Before using the machine, read carefully the entire instruction manual.
- Do not install, operate or store the device in a room smaller than 4m².

GENERAL CAUTIONS

- FOR INDOOR USE ONLY.
- Do not use in cabinet, closet, boats, caravans or similar locations.
- Do not use the unit in swimming pools, washrooms or similar wet areas.
- Leave the unit to stand for 12hours before connecting to the mains supply after transport or when it has been tilted (ex. During cleaning).
- Only use the unit in the upright position on a flat level surface (even during transport!) and at least 50cm from any objects.
- Do not use the unit in a potentially explosive environment containing combustible liquids, gases or dusts.
- Do not use the appliance in the vicinity of flammable or explosive substances or fuels. Never use any paint, cleaning sprays, anti-insect sprays or similar near the unit; this could deform the plastic or cause electrical damage.
- Ensure that there is at least 50cm between the sides of the appliance and any flammable, heating materials.
- Do not place objects on the unit or restrict air inlet/outlet.
- Avoid the unit from splash.
- Closely supervise any children and pets when the unit is in use.
- CHILDREN SHALL NOT PLAY WITH APPLIANCE.
- Cleaning and user maintenance shall not be made by children without supervision.
- Switch off and unplug the unit when not in use.

- Never leave a functioning device unsupervised.
- Do not pull the unit along by the cord.
- Avoid over-twisting, -coiling, -pulling the power cord, never use nylon or iron wire to tide the power cord.
- Make sure that the plug and socket remain visible and accessible at all the time.
- Do not use extension cords.
- Never reach to retrieve the unit if it has fallen in water. In such case, immediately pull the plug. Have the unit checked before using it again.
- The appliance shall be installed in accordance with national wiring regulations.
- Do not exceed the recommended room size for max. efficiency.
- Close the doors and windows.
- Keep curtains or blinds closed during the sunniest hours of the day.
- Keep filters clean.
- Do not turn on the appliance if you have discovered damage to the appliance, cord or plug, if the appliance is malfunctioning or if there are signs of any other defect. Return the complete product to the vendor or to a certified electrician for inspection and/or repair. Always ask for original parts. The appliance (incl. cord and plug) may only be opened and/or repaired by properly authorized and qualified persons.
- Suggest to send the unit for professional maintenance periodically.
- ONLY A LICENSED PROFESSIONAL IS ALLOWED TO DISMANTLE OR MODIFY THE APPLIANCE.
- THE MACHINE IS TO BE USED ONLY FOR ITS PRESCRIBED PURPOSE. ANY OTHER USE IS DEEMED TO BE A CASE OF MISUSE. THE USER/OPERATOR, NOT THE MANUFACTUER WILL BE LIABLE FOR ANY DAMAGE OR INJURIES OF ANY KIND CAUSED AS A RESULT OF THIS.
- Always keep the unit in vertical position.
- Keep all foreign objects away from the air intake or output openings.
- The mains supply must conform to the specification shown on the rating plate at the back of the unit.
- If the supply cord is damaged, it must be replaced by an approved service representative or a similar qualified person in order to avoid a hazard.
- Never use the plug to start and stop the unit. Always use switch on the control panel.
- Before moving the unit, first switch off, then unplug and empty the water tank.
- Don't use bug sprays or other flammable cleaners on the unit.
- Never pour or spray water over the unit.

► THIS APPLIANCE IS NOT INTENDED FOR USE BY PERSONS (INCLUDING CHILDREN) WITH REDUCED PHYSICAL, SENSORY OR MENTAL CAPABILITIES, OR LACK OF EXPERIENCE AND KNOWLEDGE, UNLESS THEY HAVE BEEN GIVEN SUPERVISION OR INSTRUCTION CONCERNING USE OF THE APPLIANCE BY A PERSON RESPONSIBLE FOR THEIR SAFETY. CHILDREN SHOULD BE SUPERVISED TO ENSURE THAT THEY DO NOT PLAY WITH APPLIANCE.

- Please do not cut off the power by pulling the wire.
- Please do not plug or unplug to startup or shut off the unit.
- Please be careful when moving the unit, do not mangle the wire.
- Please do not put fingers or sticks into the grid.
- Please prohibit child to climb, stand or sit on the unit.
- Please unplug the unit before cleaning or maintenance.

►► SAFETY RELATING TO REFRIGERANT R290:

- Read these warnings carefully.
- This appliance contains the refrigerant R290. R290 is a refrigerant that complies with the relevant European Directives. Never perforate the refrigerant circuit. R290 is flammable (GWP3)!
- Do not use means to accelerate the defrosting process or to clean, other than those recommended by the manufacturer.
- The appliance shall be stored in a room without continuously operating ignition sources (for example: open flames, an operating gas appliance or an operating electric heater).
- Do not pierce or burn any of the components of the cooling circuit of the unit. Do not set light to the unit.
- The appliance shall be stored so as to prevent mechanical damage from occurring.
- Appliance should be installed, operated and stored in a room with a floor area larger than 4m².
- Be aware that the refrigerants may not contain an odour, which means you cannot smell leaks.
- Compliance with national gas regulations shall be observed.
- Keep ventilation openings clear of obstruction.
- A warning that the appliance shall be stored in a well-ventilated area where the room size corresponds to the room area as specified for operation.
- Any person who is involved with working on or breaking into a refrigerant circuit should hold a current valid certificate from an industry-accredited assessment authority, which authorizes their competence to handle refrigerants safely in accordance with an industry recognized assessment specification.
- Servicing shall only be performed on the grounds as recommended by the equipment manufacturer. Maintenance and repair requiring the assistance of other skilled personnel shall be carried out under the supervision of the person competent in the use of flammable refrigerants.

NOTICE: WE SUGGEST THAT ANY REPAIRS SHOULD BE EXECUTED BY PROFESSIONAL SERVICEMEN

- Please make sure the unit is grounded.

- Please do not use unit in airproof conditions.
- Please follow the instructions thoroughly.

PRODUCT INTRODUCTION

Dehumidifiers can reduce air humidity in room and thus make people live comfortably and goods stored properly. Due to their neat appearance, compact configuration, high quality and easy operation, our dehumidifiers are widely used in research institutions, industry, transportation, medical centers, measuring institutions, stores, underground constructions, computer rooms, archives, warehouses, bathrooms, etc. Keeping apparatus, meters, computers, communication equipments, drugs and files away from moisture, eroding, and mildew.

►► 2. DESCRIPTION

Dehumidifier PIC. 1

- A. Control panel (display).
- B. Cover.
- C. Air outlet grille.
- D. Wheels.
- E. Transport handle. The handle must be installed by tightening the screws located on the side of the dehumidifier (Pic. 1).
- F. Cord reel hooks.
- G. Air inlet grille (contains the air filter which must be cleaned periodically. For cleaning remove the screws and remove the filter panel, clean the filter with low pressure air).
- H. Compartment for the drain pump or water recovery tank (optional tank).
- I. Drain pipe.

►► 3. CONTROL PANEL AND DISPLAY

The control panel (Pic. 2) is located on the front of the dehumidifier and includes the following icons and buttons:

- 3.1. "ON/OFF" button (A Pic. 2): This button is used to switch the dehumidifier on or off.
- 3.2. RELATIVE HUMIDITY (B Pic. 2): The indicated value is the relative humidity in the room. When the desired humidity value is set, the reference value will be shown on the display for a few seconds.
- 3.3. ROOM TEMPERATURE (C Pic. 2): The indicated value is the temperature in the room.
- 3.4. DROP ICON (D Pic. 2): The "DROP" icon indicates when the dehumidifier is operating. When the "DROP" icon lights up on the display, it means that the dehumidifier is dehumidifying. If the "DROP" icon flashes on the display, it means that the humidity in the room is lower than the humidity set on the display and the dehumidifier, only the ventilation function will work.
- 3.5. WATER DRAIN ICON (with acoustic signal) (E Pic. 2): The "WATER DRAIN" icon (Error E4) indicates that the drain pump is blocked. If the water recovery tank (OPTIONAL) is used instead of the drain pump, it means that the tank is full and must be drained manually.
- 3.6. DEFROST ICON (F Pic. 2): The "DEFROST" icon indicates when the dehumidifier is defrosting (in this stage, ventilation is stopped).
- 3.7. VENTILATION ICON (G Pic. 2): The "VENTILATION" icon indicates when the dehumidifier is in ventilation mode.
- 3.8. TIMER (H Pic. 2): Displays the time (when the delayed switch-on or switch-off mode is set, the reference time for the desired setting is displayed for a few seconds).
- 3.9. "+" / "-" BUTTONS (I Pic. 2): These buttons are used to select the desired relative humidity in the room (by lowering this value, the dehumidifier will increase performance).
- 3.10. "LIGHT" BUTTONS (L Pic. 2): This button is used to turn on the display light for a few seconds, when the dehumidifier is on.

- ▶ 3.11. "TIME" BUTTONS (M Pic. 2): This button is used to activate or disable the delayed switch-on or switch-off mode.
- Delayed switch-on: With the dehumidifier switched off, press the "TIME" button, then press the "+" / "-" buttons until the desired switch-on time is displayed.
 - Delayed switch-off: With the dehumidifier switched on, press the "TIME" button, then press the "+" / "-" buttons until the desired switch-off time is displayed.
- ▶ 3.12. "HOUR METER" BUTTONS (N Pic. 2): This button is used to set the clock. Press the "HOUR METER" button and then use the "+" / "-" buttons to set the correct time.
- NOTE: Pressing and holding the button in question for a few seconds displays the total operating hours of the dehumidifier.

SWITCH-ON

IMPORTANT: The dual voltage models (...DV) set the correct voltage automatically.

In order to switch on the dehumidifier, it must have remained in a vertical position (normal use position) for at least 12 hours. Failure to comply with this rule may cause irreparable damage to the dehumidifier.

- ▶ Follow all the safety instructions.
- ▶ Connect the power plug to the mains (SEE VOLTAGE IN "TECHNICAL DATA TABLE").
- ▶ Press the "ON/OFF" button.
- ▶ Using the "+" / "-" buttons, select the desired relative humidity in the room. If you wish to operate the dehumidifier continuously, lower the relative humidity value to the lower limit, the display will show the indication "CO". When the "DROP" icon lights up on the display, it means that the dehumidifier is dehumidifying. If the "DROP" icon flashes on the display, it means that the humidity in the room is lower than the humidity set on the display and the dehumidifier, only the ventilation function will work.

SWITCH-OFF

- ▶ Press the "ON/OFF" button.
- ▶ Disconnect the supply plug from the power mains.

WARNINGS

If the humidity set is higher than the current humidity, the dehumidifier will not start working.

If the water drain pump is blocked or the tank is full, the "WATER DRAIN" icon will light up. In the meanwhile, the compressor and the fan power supply will switch off automatically and the system will emit the acoustic signal every 5 minutes, until it is reset.

Before switching the dehumidifier off, wait at least 3 minutes. After switching it off, wait at least 3 minutes before switching it on again.

During operation, in the event of low room temperatures, the dehumidifier will automatically check the circuit temperature for defrosting. During defrosting, the indicator on the display switches on automatically, the compressor works, but the fan turns off automatically.

The display and control panel show and allow you to set the desired humidity from 30% to 90%.

If the dehumidifier is not used for a long time, disconnect the power plug from the power supply.

WATER DRAIN PIPE

The dehumidifier is equipped with a drain pump and a pipe for water drainage. The drainage pump and the pipe automatically drain the water collected from the dehumidification process. The drainage pipe allows is used to convey the waste water where required.

CAUTION: Make sure you have positioned the drain pipe correctly in a place suitable for collecting water before operating the dehumidifier [Pressure generated by the pump: water column 3 m - H₂O] (avoid blocking, crushing, etc. the piping).

CAUTION: The drain pump is activated automatically; make sure you have positioned the drain pipe correctly.

STORAGE

(Pic. 19)

The dehumidifier has been designed with specific shapes of the upper part of the cover which allow you to place a second dehumidifier on top. Make sure to perform the stacking operation in complete safety.

CAUTION: Do not stack more than one dehumidifier.

▶▶ 4. MAINTENANCE AND SAFETY

▶ FIG. 3

Do not use any relay, prolonged wire or adaptor. Otherwise, it might result in fire, radiation, or an electric shock.

▶ FIG. 4

Do not put the unit nearby stove or heater. Otherwise parts of unit might melt down or even catch fire.

▶ FIG. 5

Do not use the unit in the direct sunshine, wind or rain. (only for indoor usage)

▶ FIG. 6

In case of any other problems (for example smell of scorch), please shut off the unit and unplug it. Otherwise, it might result in fire, electric shock or other malfunctions.

▶ FIG. 7

Do not use the unit in places easily affected by chemicals. Strong chemicals might damage the unit and cause the leakage.

▶ FIG. 8

Please unplug the unit when not used for a long time.

▶ FIG. 9

When cleaning, shut off and unplug the unit. Otherwise, it might result in an electric shock.

▶ FIG. 10

When draining continuously, put the drainer for smooth drainage. If the ambient temperature is as low as freezing, do not drain continuously.

▶ FIG. 11

Do not repair or disconnect the unit yourself. Otherwise it might result in fire or an electric shock.

▶ FIG. 12

Put the unit stably. If the unit turns over, the water will flow out from the tank and damage the objects nearby. Moreover, because of the damage, it might result in fire or an electric shock

▶ FIG. 13

Make the filter more durable. When off for a long time, seal the filter in a plastic bag.

▶ FIG. 14

Do not use the unit near water. The unit might be damaged when soaked in water, so as to result in fire or electric shock.

▶ FIG. 15

Use the standard electric source of ~220-240V / 50Hz [Model ...DV (~110-120V / 50Hz) / (~220-240V / 50Hz)]. Otherwise it might result in fire or electric shock.

▶ FIG. 16

Do not damage the wire. Do not put anything heavy on the wire or heat or pull the wire. Otherwise it might result in fire of an electric shock.

▶ FIG. 17

Clean the dirt on the plug and fix it tightly. If the plug is not fixed tightly, it might cause an electric shock.

▶ FIG. 18

Do not regard the plug as a switch. Otherwise it might result in fire or an electric shock.

▶▶ **5. NOTICES ABOUT UNIT OPERATION**

▶ When moving the unit, do not tilt over 45° to avoid any damaging of the compressor.

▶ The unit should be operated between 5°~32°.

▶ When dehumidifying, because of the heat resulted from the running compressor, the indoor temperature will rise by 1°~3°. Such a reaction should be considered as normal.

▶ When indoor temperature is below 10°, and the ambient absolute humidity is quite low, it is unnecessary to use the machine.

▶ Air inlet and air outlet should be at least 10cm away from the wall.

▶ Try to keep the room closed to enhance the dehumidification effect.

▶ Too much dirt on the filter affects dehumidification, may even result in malfunctioning of it, thus it should be cleaned at least once a month. If there is a great amount of powder in the air, the filter must be cleaned once a week, or even every day. Pull the front panel out and clean the filter. If necessary, you may slightly knock all over the filter, use a vacuum cleaner to remove bigger pieces of dirt or even wash the filter in warm clean water (≤40% with some neutral detergents) and then dry it.

▶▶ **6. TROUBLE-SHOOTING****UNIT DOES NOT WORK**▶ **Analysis**

1. Power cut
2. Switch off
3. Unplugged
4. Fuse melted
5. Tank full

▶ **Solution**

1. Power on
2. Switch on
3. Plug on

4. Exchange fuse

5. Empty the tank and replace it

DEHUMIDIFIES IN INADEQUATELY▶ **Analysis**

1. Filter choked by dirt
2. Some barrier in air inlet or outlet
3. Door or windows open
4. Refrigerant leakage

▶ **Solution**

1. Clean the filter
2. Remove the barrier
3. Close the door and windows and seclude from the sunshine
4. Contact the manufacturer or seller

WATER LEAKAGE▶ **Analysis**

1. The unit is inclined
2. Drainer choked

▶ **Solution**

1. Adjust the unit to be stable
2. Pull out the panel and remove the barrier

STRANGE NOISE▶ **Analysis**

1. Until instable
2. Filter choked

▶ **Solution**

1. Place the unit stably
2. Clean the filter

▶ When above malfunctions occur and they could not be removed, please contact the supplier or seller, do not disassemble the machine yourself.

▶ When the unit starts or stops running, it makes certain noises of refrigerating circulation, which should not be considered as a malfunction.

▶ Hot air coming from the air outlet is normal.

ERROR CODES

The system automatically analyses the possible errors that may occur (see display):

ERROR CODE E1

No refrigerant.

ERROR CODE E2

Temperature sensor failure.

ERROR CODE E3

Humidity sensor failure.

ERROR CODE E4

Full water tank.

ERROR CODE E5

The sensor that checks for correct defrosting is faulty.

CE CONFORMITY CERTIFICATE



CE CONFORMITY CERTIFICATE - DICHIARAZIONE DI CONFORMITÀ CE - EG-KONFORMITÄTS-ERKLÄRUNG - DECLARACIÓN DE CONFORMIDAD CE - DECLARATION DE CONFORMITE CE - EG-CONFORMITEITVERKLARING - DECLARAÇÃO DE CONFORMIDADE CE - EU-OVERENS-STEMMELSESERKLÆRING - EY-VAATIMUSTENMUKAISUUSVAKUUTUS - CE-SAMSVARER- KLÆRING - EG-FÖRSÄKRAN OM ÖVERENSSTÄMMELSE - DEKLARACJA ZGODNOŚCI WE - ДЕКЛАРАЦИЯ О СООТВЕТСТВИИ CE - PROHLÁŠENÍ O SHODĚ CE - EK MEGFELELŐSÉGI NYILATKOZAT - IZJAVA O SKLADNOSTI IN OZNAKA CE - CE UYGUNLUK BEYANI - IZJAVA CE O SUKLADNOSTI - ES ATITIKTIES DEKLARACIJA - EK ATBILSTĪBAS - DEKLARĀCIJA - EÜ VA-STAVUSDEKLARATSIOON - DECLARAȚIE DE CONFORMITATE CE - PREHLÁSENIE O ZHODE CE - ДЕКЛАРАЦИЯ ЗА СЪВМЕСТИМОСТ CE - ДЕКЛАРАЦИЯ ВІДПОВІДНОСТІ CE - IZJAVA CE O PRIKLADNOSTI ΔΗΛΩΣΗ ΣΥΜΜΟΡΦΩΣΗΣ CE - CE 符合性声明

DANTHERM S.p.A. Via Gardesana 11, -37010- Pastrengo (VR), ITALY

Product: - Prodotto: - Produkt: - Producto: - Produit: - Product: - Produto: - Produkt: - Tuote: - Produkt: - Produkt: - Produkt: - Изделие: - Výrobek: - Termék: - Izdelek: - Ürün: - Proizvod: - Gaminys: - Ierīce: - Toode: - Produsul: - Výrobok: - Продукт: - Виріб: - Proizvod: - Προϊόν: - 产品:

DHP 55 - DHP 55DV

We declare that it is compliant with: - Si dichiara che è conforme a: - Es wird als konform mit den folgenden Normen erklärt: - Se declara que está en conformidad con: - Nous déclarons sa conformité à: - Hierbij wordt verklaard dat het product conform is met: - Declara-se que está em conformidade com: - Vi erklærer at produktet er i overensstemmel-se med: - Vakuutetaan olevan yhdenmukainen: - Man erklærer at apparatet er i overensstemmelse med: - Härmed intygas det att produkten är förenlig med följande: - Oświadczam, że jest zgodny z: - Заявляем о соответствии требованиям: - Prohlašuje se, že je v souladu s: - Kijelentjük, hogy a termék megfelel az alábbiaknak: - Izpolnjuje zahteve: - Aşağıdaki standartlara uygun olduğunu beyan ederiz: - Izjavljuje se da je u skladu s: - Pareiškiame, kad atitinka: - Tiek deklarēts, ka atbilst: - Käesolevaga deklareeritakse, et toode vastab: - Declarăm că este conform ur-mătoarelor: - Prehlasuje sa, že je v súlade s: - Декларира се че отговаря на: - Відповідає вимогам: - Izjavljuje se da je u skladu s: - Δηλώνουμε ότι είναι σύμφωνο με: - 兹证明符合:

2014/30/EU, 2014/35/EU, 2011/65/EU

**EN 60335-1:2012+A11:2014+A13:2017,
EN 60335-2-40:2003+A11:2004+A12:2005+A1:2006+A2:2009+A13:2012,
EN 55014-1:2017, EN 55014-2:2015,
EN 61000-3-2:2014, EN 61000-3-3:2013, EN 62233:2008**

Pastrengo, 2020

Stefano Verani (Member of the Board)

► en - DISPOSAL OF THE PRODUCT

-This product has been designed and manufactured with top-quality materials and components, which can be re-cycled and re-used. When a crossed-wheely bin symbol is attached to the product, it means that the product is protected by the, 2012/19/UE European Directive.

-Please obtain information regarding the local differentiated collection system for electrical and electronic products.

-Respect local Standards in force and do not dispose of old products as normal domestic waste. Correct disposal of the product helps to prevent possible negative consequences for health, the environment and mankind.

► it - SMALTIMENTO DEL PRODOTTO

-Questo prodotto è stato progettato e fabbricato con materiali e componenti di alta qualità, che possono essere riciclati e riutilizzati.

-Quando ad un prodotto è attaccato il simbolo del bidone con le ruote segnato da una croce, significa che il prodotto è tutelato dalla Direttiva Europea 2012/19/UE.

-Si prega di informarsi in merito al sistema locale di raccolta differenziata per i prodotti elettrici ed elettronici.

-Rispettare le norme locali in vigore e non smaltire i prodotti vecchi nei normali rifiuti domestici. Il corretto smaltimento del prodotto aiuta ad evitare possibili conseguenze negative per la salute dell'ambiente e dell'uomo.

► de - ENTSORGUNG DES PRODUKTS

-Dieses Produkt wurde unter Verwendung von Qualitätsmaterialien und -bauteilen entwickelt und hergestellt, die recycelt und wieder verwendet werden können.

-Ist ein Produkt gekennzeichnet durch die Mülltonne mit Rädern und einem Kreuz, wird hier angezeigt, dass dieses Produkt durch die europäische Richtlinie 2012/19/UE überwacht ist.

-Es wird gebeten, sich über die vor Ort bestehende Mülltrennung bezüglich elektrischer und elektronischer Produkte zu informieren.

-Die vor Ort geltenden Vorschriften zur Müllentsorgung müssen eingehalten werden und alte Produkte dürfen nicht zusammen mit dem Hausmüll entsorgt werden. Die ordnungsgemäße Entsorgung des Produkts hilft mögliche negative Folgen für Gesundheit und Umwelt zu vermeiden.

► es - ELIMINACIÓN DEL PRODUCTO

-Este producto ha sido diseñado y fabricado con materiales y componentes de alta calidad que se pueden reciclar y reutilizar.

-Cuando en el producto se encuentra el símbolo del contenedor con las ruedas tachado con una cruz, significa que el producto está tutelado por la Directiva europea 2012/19/UE.

-Se ruega informarse acerca del sistema local de recogida selectiva para los productos eléctricos y electrónicos.

-Respete las normas locales vigentes y no elimine los productos viejos junto con los residuos domésticos normales. La eliminación correcta del producto ayuda a evitar posibles consecuencias negativas para la salud del ambiente y del hombre.

► fr - SE DÉBARRASSER DE VOTRE PRODUIT USAGÉ

-Ce produit a été conçu et fabriqué avec des matériaux et des composants de haute qualité, qui peuvent être recyclés et utilisés de nouveau.

-Lorsque le symbole d'une poubelle à roue barrée est appliqué à un produit, cela signifie que le produit est couvert par la Directive Européenne 2012/19/UE.

-Veuillez vous informer du système local de séparation des déchets électriques et électroniques.

-Veuillez agir selon les règles locale set ne pas jeter vos produits usagés avec les déchets domestiques usuels. Jeter correctement votre produit usagé aidera à prévenir les conséquences négatives potentielles contre l'environnement et la santé humaine.

► nl - VERWIJDERING VAN HET PRODUCT

-Dit product werd ontworpen en gemaakt met hoogwaardige materialen en componenten, die gerecycleerd en herbruikt kunnen worden.

-Wanneer op een product het symbool van de afvalbak op wielen met een kruis erdoor is aangebracht, betekent dit dat het product valt onder de Europese Richtlijn 2012/19/UE.

-Gelieve inlichtingen in te winnen betreffende het plaatselijke systeem voor gedifferentieerde inzameling van elektrische en elektronische toestellen.

-Respecteer de plaatselijke normen die van kracht zijn, en verwijder de oude toestellen niet als gewoon huishoudelijk afval. Een correcte verwijdering van het product helpt om mogelijke negatieve gevolgen voor de gezondheid van mens en milieu te voorkomen.

► pt - ELIMINAÇÃO DO PRODUTO

-Este produto foi projetado e fabricado com materiais e componentes de alta qualidade que podem ser reciclados e reutilizados.

-Quando for afixado em um produto o símbolo do bidão com rodas marcado com uma cruz, significa que o produto é protegido pela Diretiva Europeia 2012/19/UE.

-Solicitamos informar-se sobre o sistema local de recolha diferenciada para os produtos elétricos e eletrônicos.

-Respeitar as normas locais em vigor e não eliminar os produtos antigos como normais detritos domésticos. A correta eliminação do produto ajuda a evitar possíveis consequências negativas para a saúde do ambiente e do homem.

► da - BORTSKAFFELSE

- Dette produkt er designet og fremstillet med materialer og dele af høj kvalitet, der kan genanvendes.
- Når et produkt er mærket med symbolet, der viser en affaldsspand på hjul med et kryds over, betyder det, at produktet er beskyttet af EF-Direktiv 2012/19/UE.
- Der henstilles til, at man informerer sig angående det lokale affaldssorteringssystem for elektriske og elektroniske produkter.
- De gældende lokale regler skal overholdes, og de gamle produkter må ikke bortskaffes sammen med husholdningsaffaldet. Ved at bortskaffe dette produkt korrekt, medvirker De til at forhindre eventuelle negative påvirkninger af miljøet og folkesundheden.

► fi - TUOTTEEN HÄVITTÄMINEN

- Tämä tuote on suunniteltu ja valmistettu korkealaatuisia materiaaleja ja osia käyttämällä, jotka voidaan kierrättää ja käyttää uudelleen.
- Kun tuotteeseen on kiinnitetty viivattu roskasäiliön merkki, se tarkoittaa, että tuotetta suojaa Euroopan yhteisön direktiivi 2012/19/UE.
- Hanki tietoja paikallisesta sähkö- ja elektroniikkaromujen erilliskeräyksestä.
- Noudata voimassa oleva määräyskiä äläkä hävitä vanhoja tuotteita kotitalousjätteiden mukana. Tuotteen oikea hävittäminen auttaa suojelemaan luontoa ja välttää väärän romutuksen aiheuttamien terveysriskien syntymistä.

► no - AVFALLSHÅNTERING

- Dette produktet er utformet og produsert med materialer og deler av høy kvalitet, og som kan gjenvinnes.
- Når det på et produkt finnes et symbol som forestiller en avfallsbeholder med et kryss over, betyr dette at produktet er underlagt EU-direktiv 2012/19/UE.
- Vennligst informer dere angående de lokale reglene som gjelder kassering av elektrisk og elektronisk avfall.
- Ta hensyn til gjeldende regelverk og ikke kast gamle produkter sammen med husholdningsavfall. Riktig avfallshåndtering av produktet bidrar til å unngå potensielle negative konsekvenser for miljøet og menneskenes helse.

► sv - PRODUKTENS BORTSKAFFANDE

- Den här produkten har projekterats och tillverkats med material och komponenter av hög kvalitet som kan återvinnas och återanvändas.
- När ett klistermärke med en symbol med överkorsad soptunna med hjul sitter på produkten, betyder detta att produkten är skyddad av EU-direktiv 2012/19/UE.
- Vi ber er inhämta upplysningar vid er lokala återvinningsstation för elektriska och elektroniska produkter.
- Följ lokala gällande bestämmelser och skaffa inte bort förbrukade produkter i det vanliga hushållsavfallet. Ett korrekt bortskaffande av produkten hjälper till att undvika möjliga negativa effekter på miljö- och människohälsa.

► pl - UTYLIZACJA PRODUKTU

- Niniejszy produkt został wyprodukowany z najwyższej jakości materiałów, które mogą być poddane recyklingowi i zostać ponownie użyte.
- Symbol przekreślonego kosza na śmieci umieszczony na sprzęcie, opakowaniu lub dokumentach do niego dołączonych oznacza, że produktowi nie wolno wyrzucać łącznie z innymi odpadami. Obowiązkiem użytkownika jest przekazanie zużytego sprzętu do wyznaczonego punktu zbiórki w celu właściwego jego przetworzenia. Oznakowanie oznacza jednocześnie, że sprzęt został wprowadzony do obrotu po dniu 13 sierpnia 2005 r.
- Należy zapoznać się z lokalnym systemem zbiórki produktów elektronicznych i elektrycznych.
- Informacje o dostępnym systemie zbierania zużytego sprzętu elektrycznego można znaleźć w punkcie informacyjnym sklepu oraz w urzędzie miasta/gminy.
- Odpowiednie postępowanie ze użytym sprzętem zapobiega negatywnym konsekwencjom dla środowiska i ludzkiego zdrowia!

► cs - LIKVIDACE VÝROBKU

- Tento výrobek byl navržen a vyroben z vysoce kvalitních materiálů a komponentů, které lze recyklovat a znovu použít.
- Je-li na výrobku symbol přeškrtnutého kontejneru, znamená to, že na výrobek se vztahuje Evropská Směrnice 2012/19/UE.
- Informujte se o místním systému pro oddělený sběr elektrických a elektronických výrobků.
- Dodržujte místní předpisy a nelikvidujte staré produkty spolu s běžným komunálním odpadem. Správná likvidace výrobku pomůže předcházet možným negativním dopadům na životní prostředí a lidské zdraví.

► hu - HULLADÉKBA HELYEZÉS

- A termék kiváló minőségű újrahaznosítható és újból felhasználható alkotóelemek felhasználásával készült.
- Ha terméken elhelyezésre került az áthúzott hulladékgyűjtő ábrázoló jel, az azt jelenti, hogy a termékre a 2012/19/UE irányelv vonatkozik.
- Kérjük, tájékozódjon az elektromos és elektronikus hulladékok szelektív gyűjtéséről.
- Tartsa be a helyben hatályos előírásokat, és ne a terméket ne helyezze a háztartási hulladékgyűjtőbe. A megfelelő hulladékgyűjtéssel elkerülhető, hogy a hulladékok károsítsák a környezetet ill. az emberi egészséget.

►sl - ODLAGANJE IZDELKA

- Ta izdelek je bil zasnovan in izdelan iz materialov in komponent visoke kakovosti, ki jih je mogoče reciklirati in ponovno uporabiti.
- Ko je izdelek označen z znamenjem prekrizanega smetnjaka na kolesih, pomeni, da zanj veljajo določbe evropske Direktive 2012/19/UE.
- Pozanimajte se o načinu ločenega zbiranja električne in elektronske opreme, ki velja v vašem kraju.
- Upoštevajte veljavne predpise in odsluženih izdelkov ne odlagajte med gospodinjske odpadke. Pravilno odlaganje izdelka prispeva k izogibanju morebitnim negativnim posledicam za zdravje okolja in ljudi.

►tr - ÜRÜNÜN İMHA EDİLMESİ

- Bu ürün, geri dönüştürülüp tekrar kullanılabilen, yüksek kaliteli malzeme ve bileşenler kullanılarak tasarlanıp üretilmiştir.
- Herhangi bir üründe, üzerinde çarpı işareti bulunan tekerlekli bidon bulunuyorsa bu, ürünün 2012/19/UE Avrupa Direktifi tarafından korunduğunu belirtir.
- Lütfen bulunduğunuz bölgedeki elektrikli ve elektronik aletler için olan çöp ayrıştırma sistemi ile ilgili bilgi edininiz.
- Konuyla ilgili yerel düzenlemelere uyunuz ve eski ürünleri normal evsel atıklarla beraber atmayınız. Ürünün doğru şekilde imha edilmesi, çevre ve insan sağlığını tehdit edici olumsuz sonuçların önlenmesine yardımcı olur.

►hr - ODBACIVANJE PROIZVODA

- Ovaj je proizvod osmišljen i izrađen s visokokvalitetnim materijalima i komponentama koje se mogu reciklirati i ponovno iskoristiti.
- Kada se na proizvod stavi simbol prekrizene kante na kotačima, to znači da je on podvrgnut Europskoj Smjernici 2012/19/UE.
- Informirajte se u svezi s lokalnim načinom diferencijalnog sakupljanja električnih i elektronskih proizvoda.
- Pošaljite lokalne propise na snazi i ne odbacujte stare proizvode zajedno sa običnim kućnim otpadom. Pravilnim odbacivanjem proizvoda spriječit ćete moguće negativne posljedice za okoliš i za zdravlje ljudi.

►lt - GAMINIO SUNAIKINIMAS

- Šis gaminys buvo sukurtas ir pagamintas iš aukštos kokybės medžiagų bei dalių, kurios gali būti perdirbtos arba panaudotos dar kartą.
- Kai gaminys yra pažymėtas perbraukto atliekų konteinerio su ratukais ženklu, tai reiškia, kad gaminys yra saugomas pagal ES direktyvą 2012/19/UE.
- Prašome pasidomėti apie vietinę elektros ir elektronikos atliekų rūšiavimo sistemą.
- Laikykitės vietinių galiojančių taisyklių ir nemeskite senų gaminių su įprastomis buitinėmis atliekomis. Tinkamai sunaikinę gaminį išvengsite galimų neigiamų pasekmių aplinkai ir žmonių sveikatai.

►lv - PRODUKTA IZNĪCINĀŠANA

- Šis produkts tika izveidots un ražots ar augstas kvalitātes materiāliem un sastāvdaļām, kas var būt savāktas un atkārtoti izmantotas.
- Kad pie produkta ir piestiprināts atkritumu tvertnes simbols ar riteņiem, kas ir pārsvītrots ar krustu, tas nozīmē, ka produktu aizstāv Eiropas Direktīva 2012/19/UE.
- Lūdzam Jūs gūt informāciju par vietēju centru, kas savāc elektriskās un elektroniskā ierīces.
- Ievērot vietējās pastāvošās normas un neiznīcināt vecus produktus, kā parastus mājas atkritumus. Produkta pareizā iznīcināšana palīdz izvairīties no iespējamām negatīvām sekām vides un cilvēku veselībai.

►et - TOOTE KASUTUSEST KÕRVALDAMINE

- See toode on projekteeritud ja toodetud kvaliteetsetest materjalidest ja osadest, mida võib uuesti ringlusse võtta ja korduskasutada.
- Kui tootel on märk, millel on ratastega prügikast, millele on rist peale tõmmatud, tähendab see, et toodet kaitseb Euroopa direktiiv 2012/19/UE.
- Palun tutvuge kohaliku elektri- ja elektroonikatoodete lahuskogumise süsteemiga.
- Täitke kehtivaid kohalikke õigusnorme ning ärge visake vana toodet olmejäätmete hulka. Toote õige kõrvaldamine aitab vältida võimalikke negatiivseid tagajärgi keskkonna ja inimeste tervisele.

►ro - SCOATEREA DEFINITIVĂ DIN UZ A PRODUSULUI

- Acest produs a fost proiectat și fabricat cu materiale și componente de înaltă calitate care pot fi reciclate și refolosite.
- Când pe produs este aplicat simbolul unei pubele cu roți, marcată cu o cruce, înseamnă că produsul respectiv este conform Directivei Europene 2012/19/UE.
- Vă rugăm să vă informați în ceea ce privește colectarea separată a produselor electrice și electronice.
- Respectați normele locale în vigoare și nu depozitați produsele vechi împreună cu deșeurile menajere. Eliminarea corectă a produsului ajută la eliminarea consecințelor negative pe care acesta le poate avea asupra mediului înconjurător și a persoanelor.

►sk - LIKVIDÁCIA VÝROBKU

- Tento výrobok bol navrhnutý a vyrobený z vysoko kvalitných materiálov a komponentov, ktoré je možné recyklovať a znovu použiť.
- Ak je na výrobku symbol prečiarknutého kontajnera, znamená to, že na výrobok sa vzťahuje Európska Smernica 2012/19/UE.
- Informujte sa o miestnom systéme pre oddelený zber elektrických a elektronických výrobkov.
- Dodržujte miestne predpisy a nelikvidujte staré produkty spolu s bežným komunálnym odpadom. Správna likvidácia výrobku pomôže predchádzať možným negatívnym dopadom na životné prostredie a ľudské zdravie.

► bg - ИЗХВЪРЛЯНЕ НА УРЕДА

-Това изделие е проектирано и произведено с материали и компоненти от високо качество, които могат да се рециклират или използват повторно.

-Когато на някое изделие е поставен символ с бидон на колелца, маркиран с хикс, това означава, че изделието е защитено съгласно Европейска Директива 2012/19/UE.

-Моля да се информирате относно местанат система за разделно изхвърляне на електрически и електронни изделия.

-Спазвайте действащите местни нормативи и не изхвърляйте изделията, заедно с нормалните домакински отпадъци. Правилното изхвърляне на изделията, помага за избягване на възможни отрицателно последици, за здравето на хората и за опазване на околната среда.

► uk - УТИЛІЗАЦІЯ ВИРОБУ

-Цей виріб був спроектований і вироблений з використанням високоякісних матеріалів і комплектуючих, які можуть бути повторно перероблені і використані.

-Якщо на виріб нанесено символ перекресленого бака з колесами для сміття, це означає, що виріб відповідає Директиві Європейського Союзу 2012/19/UE.

-Просимо ознайомитися з інформацією щодо місцевої системи роздільного збору сміття для електричного і електронного обладнання.

-Дотримуйтеся чинних місцевих правил і не викидайте старі вироби до звичайних побутових відходів. Правильна утилізація виробу допомагає уникнути можливих негативних наслідків для довкілля і здоров'я людей.

► bs - ODLAGANJE PROIZVODA

-Ovaj je proizvod dizajniran i proizveden korištenjem materijala i komponenata visoke kvalitete koji se mogu reciklirati i ponovo koristiti.

-Kada se na ovaj proizvod postavi simbol prekrížene kante /obilježene krstom na točkovima, to znači da je proizvod podložan Evropskoj Direktivi 2012/19/UE.

-Molimo Vas da se informirate o lokalnom sistemu diferencijalnog sakupljanja električnih i elektronskih proizvoda.

-Poštujte lokalne propise na snazi i ne odbacujte stare proizvode u obični kućanski otpad. Pravilno odlaganje proizvoda pomaže i onemogućuje negativne posljedice za zdravlje ljudi i okoliša

► el - ΔΙΑΘΕΣΗ ΤΟΥ ΠΡΟΪΟΝΤΟΣ

-Το προϊόν αυτό σχεδιάστηκε και κατασκευάστηκε με υλικά και εξαρτήματα υψηλής ποιότητας, τα οποία μπορούν να ανακυκλωθούν και να ξαναχρησιμοποιηθούν.

-Όταν ένα προϊόν είναι συνδεδεμένο με το σύμβολο του διαγεγραμμένου τροχοφόρου σημειωμένο με ένα σταυρό, σημαίνει ότι το προϊόν καλύπτεται από την Ευρωπαϊκή Οδηγία 2012/19/UE.

-Σας συνιστούμε να ενημερωθείτε σχετικά με το τοπικό σύστημα συλλογής για την ανακύκλωση ηλεκτρικών και ηλεκτρονικών προϊόντων.

-Τηρήστε τους τοπικούς κανονισμούς που ισχύουν και μην απορρίπτετε τα παλαιά προϊόντα στα οικιακά απορρίμματα. Η σωστή διάθεση του προϊόντος βοηθά στην αποφυγή πιθανών αρνητικών συνεπειών για την υγεία του περιβάλλοντος και του ανθρώπου.

► zh - 弃置旧的产品

-该产品是由高质量的原材料和零配件生产而成的，可以进行回收再利用

-当这个标识标签出现在产品上时，它表明这个产品符合 European Directive 2012/19/UE 标准。

-请熟知产品实际使用地关于处理废弃的电子元件的相关法律规定。

-请严格根据当地法规处理废弃的产品和包装，并确保不和生活垃圾混装。正确的处理方式可以避免对环境和人体健康产生的潜在威胁。

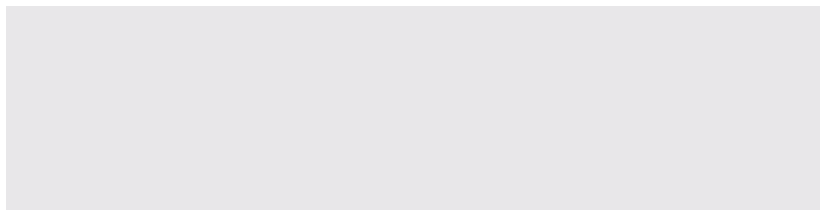

NOTE:



Recycling



ENVIRONMENTAL PROTECTION: Please recycle any unwanted materials as opposed to disposing them as general waste. It is recommended the original is retained and used to store the product when not in use for prolonged periods of time. If this is not applicable ensure the materials are sorted and recycled in accordance with local regulations.



SPECIFICATION CHANGE: It is our policy to continually improve products to ensure these meet the rigours of the industry we serve. Therefore, as such we reserve the right to alter specifications, data, components & parts with-out prior notice.

WARRANTY: Please refer to the manufactures terms & conditions.

IMPORTANT: No liability will be accepted for the incorrect use of this product.

KEEP THIS BOOKLET FOR FUTURE REFERENCE

📞 Nottingham: 0115 946 1988 • London: 0208 830 3333 ✉ Nottingham: sales@hscgroupuk.co.uk • London: sean@hscgroupuk.co.uk 🌐 www.hscgroupuk.co.uk

The Hire Supply Company Terms & Conditions Apply At All Time E&OE