

# Charmline®



Only suitable for well insulated areas and not designed  
to be the primary heat source

## 15KW ELECTRIC FAN HEATER

MODEL NO: DEVIL 7015

PART NO: 6935456

### OPERATION & MAINTENANCE INSTRUCTIONS

UK  
CA | CE



ORIGINAL INSTRUCTIONS

DL1123 Rev 10

---

## **INTRODUCTION**

---

Thank you for purchasing this CLARKE product.

Before attempting to use this product, please read this manual thoroughly and follow the instructions carefully. In doing so you will ensure the safety of yourself and that of others around you, and you can look forward to your purchase giving you long and satisfactory service.

---

## **GUARANTEE**

---

This product is guaranteed against faulty manufacture for a period of 12 months from the date of purchase. Please keep your receipt which will be required as proof of purchase.

This guarantee is invalid if the product is found to have been abused or tampered with in any way, or not used for the purpose for which it was intended.

Faulty goods should be returned to their place of purchase, no product can be returned to us without prior permission.

This guarantee does not effect your statutory rights.

---

## **FUNCTION AND OPERATING PARAMETERS**

---

This is a forced air heater. It's intended use is for drying and the warming of commercial/industrial buildings and areas where adequate ventilation is provided.

- It must be operated as prescribed in the operating manual.
- It is not intended to be used for domestic use or for the heating of habitable areas.
- It is not intended to be used to reach and maintain a certain level of human thermal comfort within an enclosed space in which the heater is situated.
- It is not intended to be used in enclosed areas with restricted ventilation.
- It is not intended for warming animals or live stock.

**THE FOLLOWING TABLE ADDRESSES THE INFORMATION REQUIREMENTS OF REG.2015/1188**

Item	Symbol	Value	Unit
<b>Heat output</b>			
Measured seasonal space heating energy efficiency			36%
Nominal heat output	$P_{nom}$	15	kW
Minimum heat output (indicative)	$P_{min}$	0	kW
Maximum continuous heat output	$P_{max}$	15	kW
<b>Auxiliary electricity consumption</b>			
At nominal heat output	$e_{l_{max}}$	n/a	kW
At minimum heat output	$e_{l_{min}}$	n/a	kW
In standby mode	$e_{l_{SB}}$	0	kW
<b>Type of heat input for electric storage local heaters only</b>			
Manual heat charge control with integrated thermostat			No
Manual heat charge control with room and/or outdoor temperature feedback			No
Electronic heat charge control with room and/or outdoor temperature feedback			No
Fan assisted output			No
<b>Type of heat output/room temperature control (select one)</b>			
Single stage heat output, no temperature control			No
Two or more manual stages, no temperature control			No
With mechanical thermostat temp control			Yes
With electronic temperature control			No
Electronic temperature control with day timer			No
Electronic temperature control with week timer			No
<b>Other control options (multiple selections possible)</b>			
Room temperature control with presence detection			No
Room temperature control with open window detection			No
Room temperature control with distance control option			No
Room temperature control with adaptive start control			No
Room temperature control with working time limitation			No
Room temperature control with black bulb sensor			No

---

## SAFETY SYMBOLS

---

The following symbols appear on the unit.

	Hot Surface, Do Not Touch	 DO NOT COVER	Do Not Cover		High Voltage
---	------------------------------	---	--------------	---	--------------

---

## SAFETY RULES

---

Make sure that you read, understand and comply with the following.

### ELECTRICAL SAFETY

---



#### WARNING: THIS HEATER MUST BE EARTHED

1. Electrical appliances must match the power outlet. **NEVER** modify the plug in any way. **DO NOT** use adaptor plugs with earthed (grounded) appliances. Correct plugs and outlets will reduce the risk of electric shock.
2. **DO NOT** abuse the electrical cable. **NEVER** use the cable for pulling or unplugging the heater. Keep the cable away from sources of heat, oil, sharp edges or moving parts. Damaged or tangled cables increase the risk of electric shock.
3. Keep the power cable well away from machines and ensure an adequate electrical supply is close at hand so that the operation is not restricted by the length of the cable.
4. **ALWAYS** disconnect from the power supply before moving the heater or performing any cleaning or maintenance tasks.
5. Inspect the mains cable regularly for signs of damage. **DO NOT** use if it is damaged, and **ALWAYS** keep it away from the source of heat.
6. Check the heater for damage before use. **DO NOT** use if the heater tubes/elements are damaged or broken. Any damage should be properly repaired or the part replaced. If in doubt, **DO NOT** use. Consult your local CLARKE dealer.

## MAINTENANCE.

---



**WARNING: SERVICING OR INTERNAL MAINTENANCE MUST ONLY BE CARRIED OUT BY THE CLARKE SERVICE DEPARTMENT.**

---

1. Check that the heater is in good working order. Take immediate action to repair or replace damaged parts.
2. **DO NOT** allow the heating elements to become covered with dust which could become a fire hazard. If used in a dusty workplace it should be cleaned as described under Cleaning and Maintenance.
3. Only recommended parts should be used. Unapproved parts may be dangerous and will invalidate the warranty.
4. **DO NOT** attempt to repair a damaged heater, contact the Clarke service department.

## POSITIONING

---



**WARNING: DO NOT USE THE HEATER NEAR FLAMMABLE MATERIAL, LIQUIDS, SOLIDS, GASSES OR COMPRESSED GAS CYLINDERS ETC.**

---

1. This heater is designed for indoor use only.
2. **DO NOT** use this heater in small rooms when they are occupied by persons not capable of leaving the room on their own unless constant supervision is provided.
3. **DO NOT** use this heater in the immediate surrounds of a bath, a shower, a swimming pool or wet surfaces.
4. **NEVER** place the heater against or near any surface such as a wall, door, curtains, furniture or combustible material etc. Allow at least 2 metre clearance.
5. **DO NOT** place the heater immediately below any electrical outlet.
6. **DO NOT** place the heater on a raised surface or anywhere where it could topple over. **ALWAYS** use on a horizontal and stable surface.
7. **ALWAYS** ensure that the grille cannot be blocked.
8. **DO NOT** operate fan heaters in explosive atmospheres such as in the presence of flammable liquids, gasses or dust such as in a paint spray booth or any explosive environment. Electric motors create sparks which may ignite dust or fumes.

## OPERATION

1. This heater is intended for drying & warming of commercial/industrial buildings where adequate ventilation is provided. It is **NOT** for domestic use or for heating habitable areas.
2. The heater should **NOT** be used by children or persons with reduced physical, sensory or mental capabilities, or lack of experience and knowledge.
3. **CAUTION:** Some parts of this product can become very hot and cause burns. Particular attention should be given where, animals, children and vulnerable people are present.
4. The heater must only be used by people who have read these instructions and have been trained in its use.
5. **DO NOT** use if dropped.
6. **DO NOT** use if there is visible signs of damage.
7. **DO NOT** obstruct the air inlet and outlet sections of the heater.
8. **DO NOT** cover the heater with anything that could restrict the air flow.
9. **DO NOT** touch the heater casing or grille when first switched off, as these will be very hot and will take time to cool.
10. **DO NOT** get the heater wet or use in areas of high condensation.
11. **DO NOT** allow the power lead to touch hot surfaces.
12. **DO NOT** connect other appliances to the same mains socket as the heater.
13. **DO NOT** use this heater with a programmable timer used to switch it on automatically.
14. **DO NOT** leave the heater unattended.

## SERVICE & REPAIRS

1. If necessary, have your heater repaired by a qualified person using identical replacement parts. This will ensure that the safety of the product is maintained.
2. Please keep these instructions in a safe place for future reference.

---

# ELECTRICAL CONNECTIONS

---



**WARNING: THE INSTALLATION OF THIS APPLIANCE SHOULD BE CARRIED OUT BY A COMPETENT ELECTRICIAN AND BE IN ACCORDANCE WITH THE CURRENT IEE WIRING REGULATIONS (BS7671-2:2008).**

---

This machine **MUST** be connected to a 400 Volt, 3 phase 50Hz supply through a suitably rated isolator switch. It cannot be operated from a single phase supply.

The user should purchase a suitable connecting cable capable of handling 32 Amps (recommended Cross Sectional Area 6mm<sup>2</sup>) and supply plug rated at 32A (or better) which complies with BSEN 60309. A length of 2-3 metres is recommended giving mobility to the appliance but without becoming a trip hazard

If in any doubt, consult a qualified electrician. **DO NOT** attempt any electrical work yourself.

---

## SAFETY SYSTEMS

---

### THERMOSTATIC PROTECTION

The Devil 7015 has a thermal cut out to prevent the unit from overheating.

The thermal cutout may also operate if the heater is shut down without allowing to cool sufficiently. If subsequently, the heater fails to start, use a suitable tool to press the RESET button and try again.

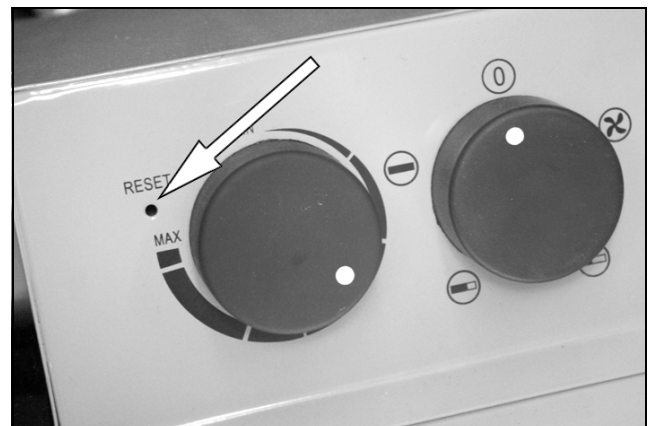

# LIST OF PACK CONTENTS

1 x Heater	1 x Axle c/w Circlip (2)
1 x R/H & 1 x L/H Support Frames	2 x Wheel
1 x Upper Handle	1 x Fixings Pack

## ASSEMBLY

1. Fit the right leg frame to the main body as shown.

**NOTE:** The bolt needs to be inserted before the handwheel.

**NOTE:** The bolt goes through the larger of the 2 holes in the spacer.

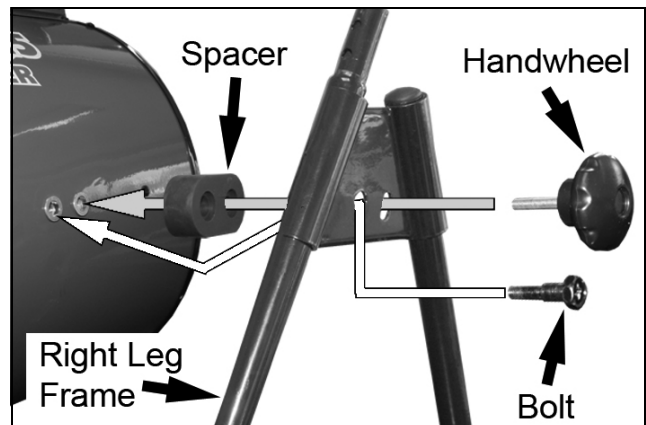

2. Fit the axle and left hand support frame.

**NOTE:** The circlip shown must be on the inside of the legs.

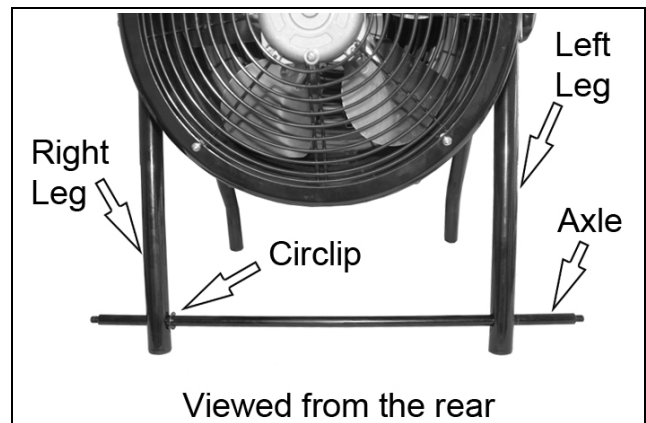

3. Fit the wheels as shown.

**NOTE:** The cap fits over the flat washer.

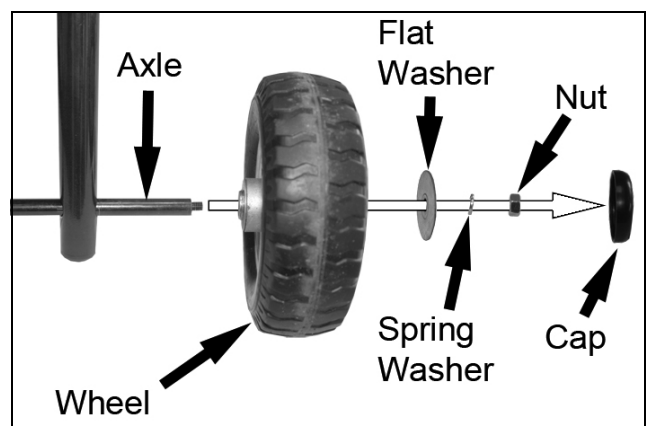



4. Use the nuts and bolts supplied, to secure the handle to the leg frames as shown.

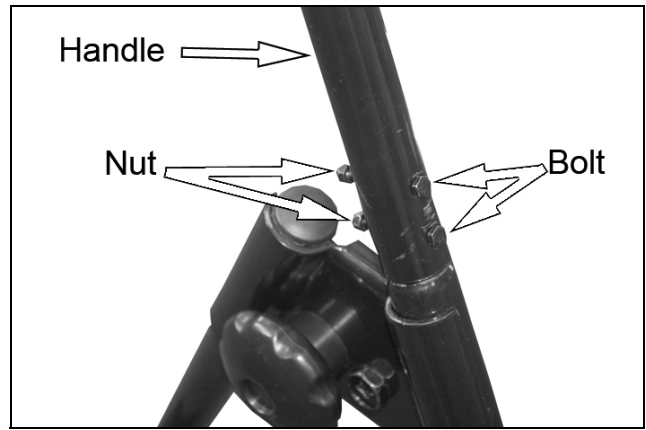

---

## OPERATION

---



**WARNING: DO NOT USE THIS HEATER IN SMALL ROOMS WHEN THEY ARE OCCUPIED BY PERSONS NOT CAPABLE OF LEAVING THE ROOM ON THEIR OWN, UNLESS CONSTANT SUPERVISION IS PROVIDED.**





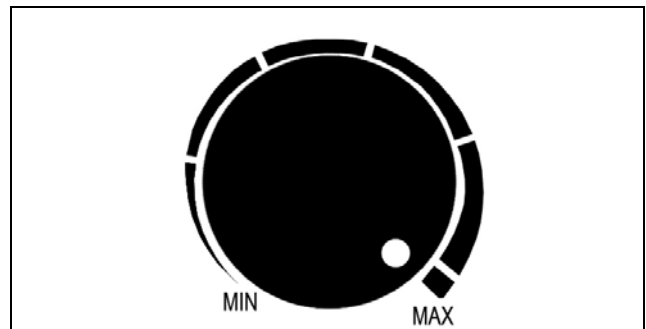

**CAUTION: SOME PARTS OF THIS PRODUCT CAN BECOME VERY HOT AND CAUSE BURNS. PARTICULAR ATTENTION HAS TO BE GIVEN WHERE CHILDREN AND VULNERABLE PEOPLE ARE PRESENT.**

1. Put the heater in a level position on a flat surface and at a safe distance from flammable materials. Keep a minimum of 2m clearance all round.
2. Connect the heater to a suitable power supply.
3. Set the thermostat control to the maximum setting (fully clockwise).



4. Set the mode selector to one of the settings:

0	Off
	Fan Only
	Low Heat Setting
	Medium Heat Setting
	High Heat Setting

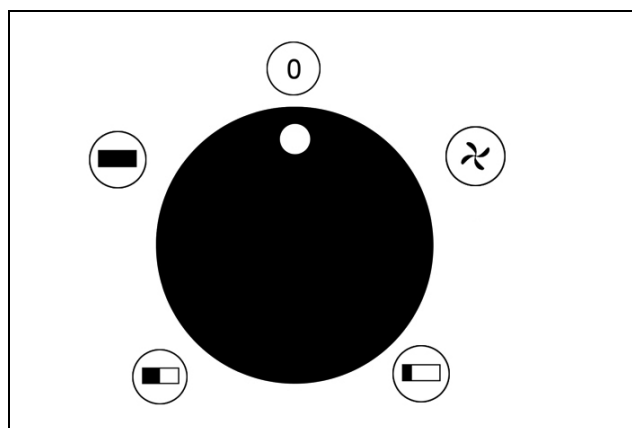

- The heater will take up to three minutes to reach optimum temperature.
5. Once the room reaches the required temperature, turn the thermostat control slowly counter-clockwise until the thermostat clicks, leave the control in this position.
    - The room temperature will be maintained at this setting. The heater will continue to operate until the mode selector is turned to the OFF position.
  6. For fan only operation, turn the mode selector to the fan only setting and set the thermostat to its minimum setting.
  7. Turn the heater off by turning the mode selector to "0",
    - Do not remove the plug from the mains supply. The fan will continue to run for several minutes to lower the temperature of the case and elements. Once the fan stops you can safely remove the plug from the power supply.
  8. When not in use, disconnect the heater from the mains supply. Store it in a safe, dry, childproof location.

---

# MAINTENANCE

---



**WARNING: ALWAYS DISCONNECT FROM THE POWER SUPPLY AND ALLOW THE HEATER IT TO COOL DOWN BEFORE PERFORMING ANY MAINTENANCE TASKS.**

---

- Clean the heater with a soft damp cloth, Do not use solvents or abrasives.
  - Make sure that the heater grill is not blocked.
  - No other maintenance is required, should you discover any problem with the heater, return it to the Clarke service department for repair.
- 

# SPECIFICATIONS

---

Operating Voltage, Current and Frequency: (V / A / Hz / Phs)	400 V / 23A / 50Hz / 3 Phase
Operating Temperature: (Min/Max) (°C):	0-40°C
Heat Output: (kW):	15 kW
Air Output: (m <sup>3</sup> /h)	941m <sup>3</sup> /h
Safety Device:	Thermal cut-out
Duty Cycle Classification:	Continuous duty
Electrical Insulation Class	I
Product: Depth x Width x Height	512 x 540 x 852 mm
Product Weight	19.8 kg

## TROUBLE SHOOTING

Problem	Possible Cause	Remedy
Heater does not operate, although plugged in with the switch and thermostat switched on.	Plug is loose/bad connection.	Pull the plug out & check all connections (cable/plug and socket).
	Fuse blown or circuit breaker trips.	Replace if necessary and investigate cause. If fuse blows repeatedly, consult your Clarke dealer.
	No power at socket outlet	Insert the plug in a suitable socket
Heating element glowing hot.	Input voltage too high or too low.	Use a power supply in accordance with the rating on the label.
	Air inlet grille is blocked	Ensure the heater is kept away from any objects which could cover the air inlet or be drawn into it.
The unit has failed to heat up so only the air fan has operated.	Control switch not set at a "HEATING" level.	Turn switch to a heating level.
	Thermostat has tripped.	Turn the thermostat and listen. If there is no CLICK and the thermostat is not damaged, the heater will automatically switch ON when it has cooled down.
Abnormal noise.	Heater is not level.	Stand heater on a level surface

## ENVIRONMENTAL RECYCLING POLICY



Through purchase of this product, the customer is taking on the obligation to deal with the WEEE in accordance with the WEEE regulations in relation to the treatment, recycling & recovery and environmentally sound disposal of the WEEE.

In effect, this means that this product must not be disposed of with general household waste. It must be disposed of according to the laws governing Waste Electrical and Electronic Equipment (WEEE) at a recognised disposal facility.

# PARTS DIAGRAM

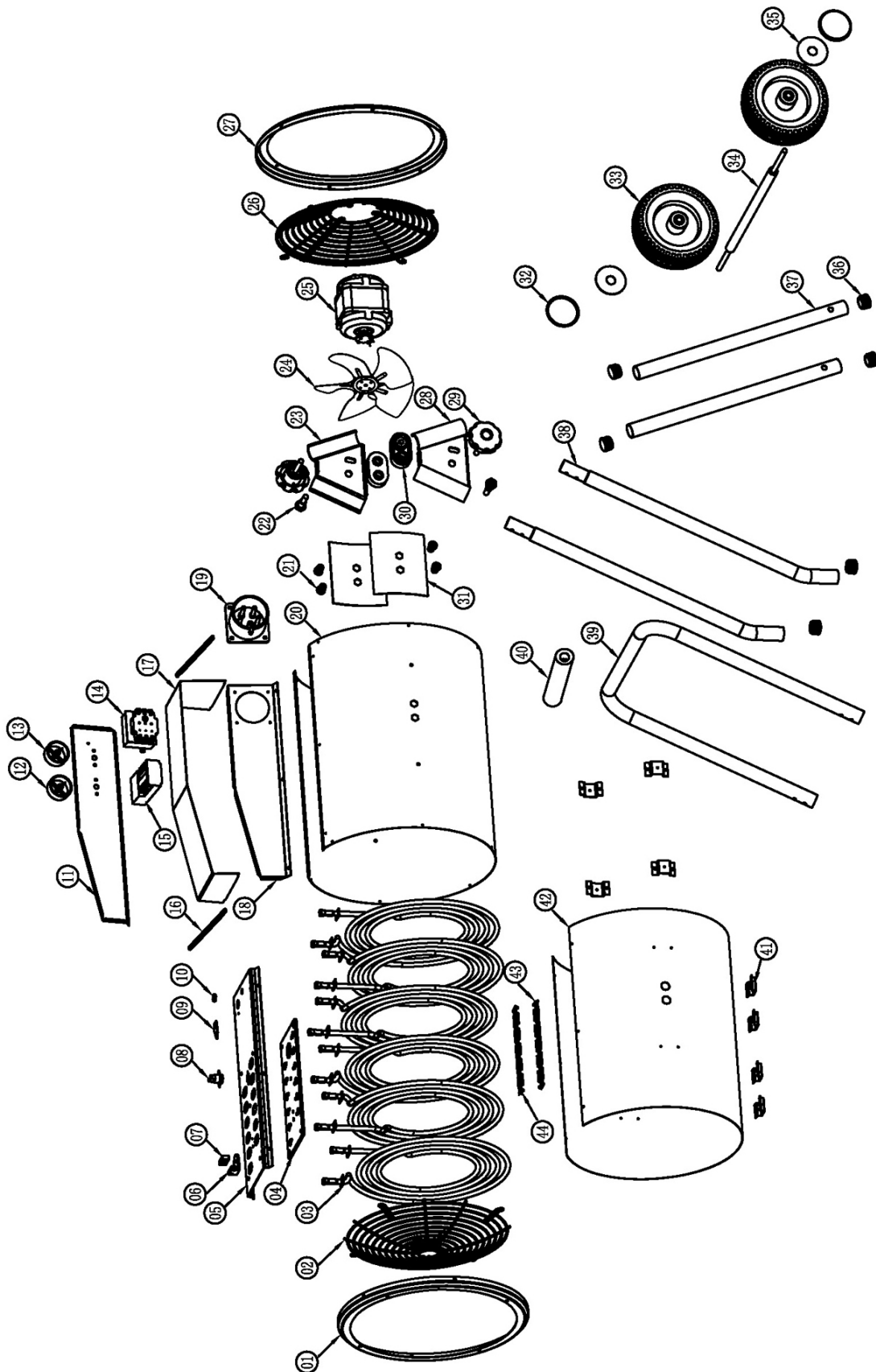



## PARTS LIST

1	Front Rings	23	Securing Plate R
2	Front Grille	24	Fan
3	Heating Elements	25	Motor
4	Insulate Board	26	Rear Grille
5	Chassis Panel	27	Rear Rings
6	Temperature Retaining Clip	28	Securing Plate L
7	Temperature Retaining Clip	29	Adjustable Screw
8	After Cooling Sensor	30	Spacer
9	Retaining Plate	31	Securing Plate
10	Grommet	32	Decoration Cap
11	Control Panel	33	Wheel
12	Switch Knob	34	Axle
13	Thermostat Knob	35	Securing Plate
14	Temperature Controller	36	Base Pad
15	Speed Controller	37	Rear Frame
16	Sealing Tape	38	Front Frame
17	Control Box Cover	39	Upper Frame
18	Socket Panel	40	Insulate Sleeve
19	5 Pin Socket	41	Location Plate
20	House Casing	42	Heat Shield
21	Rivet Nut	43	Heater Bracket Upper
22	Fixing Bolt	44	Heater Bracket Bottom

Part number = (CXDEV7015 + the number of the part)

# DECLARATION OF CONFORMITY - UKCA & CE

 <b>Clarke</b> INTERNATIONAL Hemnal Street, Epping, Essex CM16 4LG	<b>DECLARATION OF CONFORMITY</b> This is an important document and should be retained.
<p>We hereby declare that this product(s) complies with the following statutory requirement(s):</p> <ul style="list-style-type: none"><li>Electromagnetic Compatibility Regulations 2016</li><li>Electrical Equipment (Safety) Regulations 2016</li><li>The Restriction of the Use of Certain Hazardous Substances in Electrical and Electronic Equipment Regulations 2012</li><li>The Eco-design for Energy Related Products and Energy Information (Amendment) (EU Exit) Regulations 2019</li></ul>	
<p>The following standards have been applied to the product(s):</p> <ul style="list-style-type: none"><li>EN 55014-1:2017, EN 55014-2:2015, EN 61000-3-2:2014, EN 61000-3-3:2013, EN 61000-3-11:2000, EN 61000-3-12:2011, EN 60335-2-30:2009+A11:2012, EN 62233:2008,</li><li>EN 60335-1:2012+AC:2014+A11:2014+A13:2017, IEC 62321-3-1:2013, IEC 62321-4:2013,</li><li>IEC 62321-5:2013, IEC 62321-6:2015, IEC 62321-7-1:2015, IEC 62321-7-2:2017, IEC 62321-8:2017, IEC/EN 60675:1998, IEC 62301:2011</li></ul>	
<p>The technical documentation required to demonstrate that the product(s) meet(s) the requirement(s) of the aforementioned legislation has been compiled and is available for inspection by the relevant enforcement authorities.</p> <p>The UKCA mark was first applied in: 2022</p>	
<p><b>Product Description:</b> Electric Fan Heaters – 5kW, 9kW, 15kW, 22kW, 30kW</p> <p><b>Model number(s):</b> Devil 7005, Devil 7009, Devil 7015, Devil 7025, Devil 7030</p> <p><b>Serial / batch Number:</b> N/A</p> <p><b>Date of issue:</b> 13/04/2022</p>	<p><b>Signed:</b>  J.A. Clarke Director</p>
<p>Devil 7015 UKCA Clarke DOC 041322 Page 1 of 1</p>	

 <b>Clarke</b> INTERNATIONAL Fitzwilliam Hall, Fitzwilliam Place, Dublin 2	<b>DECLARATION OF CONFORMITY</b> This is an important document and should be retained.
<p>We hereby declare that this product(s) complies with the following directive(s):</p> <ul style="list-style-type: none"><li>2014/30/EU Electromagnetic Compatibility Directive</li><li>2014/35/EU Low Voltage Directive</li><li>2011/65/EU Restriction of the Use of Certain Hazardous Substances in Electrical and Electronic Equipment Directive</li><li>2009/125/EC Eco-design Directive</li></ul>	
<p>The following standards have been applied to the product(s):</p> <ul style="list-style-type: none"><li>EN 55014-1:2017, EN 55014-2:2015, EN 61000-3-2:2014, EN 61000-3-3:2013, EN 61000-3-11:2000, EN 61000-3-12:2011, EN 60335-2-30:2009+A11:2012, EN 62233:2008,</li><li>EN 60335-1:2012+AC:2014+A11:2014+A13:2017, IEC 62321-3-1:2013, IEC 62321-4:2013,</li><li>IEC 62321-5:2013, IEC 62321-6:2015, IEC 62321-7-1:2015, IEC 62321-7-2:2017, IEC 62321-8:2017, IEC/EN 60675:1998, IEC 62301:2011</li></ul>	
<p>The technical documentation required to demonstrate that the product(s) meet(s) the requirement(s) of the aforementioned directive(s) has been compiled and is available for inspection by the relevant enforcement authorities.</p> <p>The CE mark was first applied in: 2014</p>	
<p><b>Product Description:</b> Electric Fan Heaters – 5kW, 9kW, 15kW, 22kW, 30kW</p> <p><b>Model number(s):</b> Devil 7005, Devil 7009, Devil 7015, Devil 7025, Devil 7030</p> <p><b>Serial / batch Number:</b> N/A</p> <p><b>Date of issue:</b> 13/04/2022</p>	<p><b>Signed:</b>  J.A. Clarke Director</p>
<p>Devil 7015 CE Clarke DOC 041322 Page 1 of 1</p>	

# A SELECTION FROM THE VAST RANGE OF

# Clarke®

## QUALITY PRODUCTS



### **AIR COMPRESSORS**

From DIY to industrial, Plus air tools, spray guns and accessories.

### **GENERATORS**

Prime duty or emergency standby for business, home and leisure.

### **POWER WASHERS**

Hot and cold, electric and engine driven - we have what you need

### **WELDERS**

Mig, Arc, Tig and Spot. From DIY to auto/industrial.

### **METALWORKING**

Drills, grinders and saws for DIY and professional use.

### **WOODWORKING**

Saws, sanders, lathes, mortisers and dust extraction.

### **HYDRAULICS**

Cranes, body repair kits, transmission jacks for all types of workshop use.

### **WATER PUMPS**

Submersible, electric and engine driven for DIY, agriculture and industry.

### **POWERTOOLS**

Angle grinders, cordless drill sets, saws and sanders.

### **STARTERS/CHARGERS**

All sizes for car and commercial use.

## **PARTS & SERVICE: 0208 988 7400**

**Parts Enquiries**  
[Parts@clarkeinternational.com](mailto:Parts@clarkeinternational.com)

**Servicing & Technical Enquiries**  
[Service@clarkeinternational.com](mailto:Service@clarkeinternational.com)

SALES: UK 01992 565333 or Export 00 44 (0)1992 565335

**Clarke** INTERNATIONAL Hemnall Street, Epping, Essex CM16 4LG  
[www.clarkeinternational.com](http://www.clarkeinternational.com)