

Compact Cassette 600x600

PRODUCT SHEET

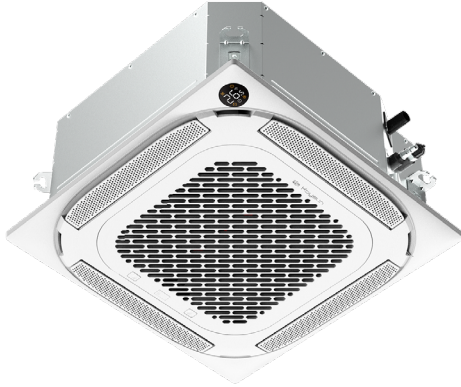

KID-06 S
Recommended controller

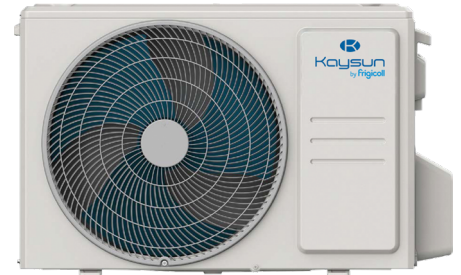

Product certified by:



FEATURES

Model	KCIA-26 DVR15
Cooling capacity	2,63 kW
Cooling power input	800 W
Heating capacity	3,07 kW
Heating power input	1.019 W
ErP Classification cold/heat	A++ / A+
Airflow (indoor)	330 / 520 / 620 m ³ /h
Sound pressure (indoor)	25,5 / 31,5 / 38,5 / 42 dB(A)
Airflow (outdoor)	2.000 m ³ /h
Sound pressure (outdoor)	54 dB(A)
Power supply	220-240 V / 1 / 50 Hz
Max. input	9 A
Power wiring (indoor)	With communication
Power wiring (outdoor)	(2+T)x1,50 mm ²
Communication wiring	(3+T)x1 mm ²

WIRING DIAGRAM

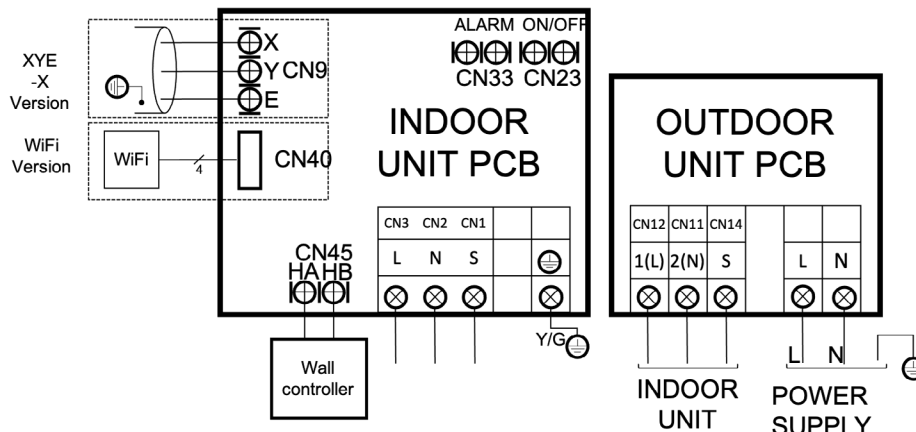

NOTES:

(1) The data and specifications present in this sheet may vary without notice.

(2) The images on this sheet are indicative and may be different from the final machine.



COOLING CONNECTION

Model	KCIA-26 DVR15	
Refrigerating pipes	Ø1/4" / Ø3/8"	
Refrigerant charge / Additional charge	0,65 kg / 0,012 kg	
Indoor drain pipe	Ø25	
Max. pipe length (A)	25 m	
Max. level difference (B)	10 m	

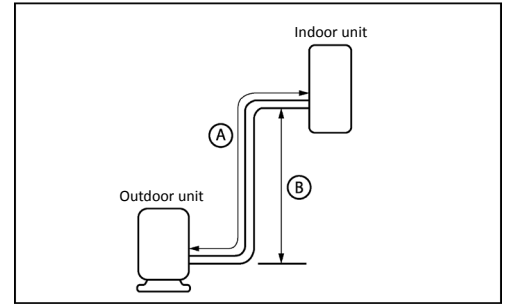

DIMENSIONS & WEIGHT INDOOR

Model	KCI-26 DVR15	
Weight	16,10 kg	

DIMENSIONS & WEIGHT OUTDOOR

Model	KUE-26 DVR14	
Width	765 mm	
Height	555 mm	
Depth	303 mm	
Weight	26,60 kg	

DIMENSIONS & WEIGHT PANEL

Model	KPA-03B 600x600	
Weight	2,70 kg	

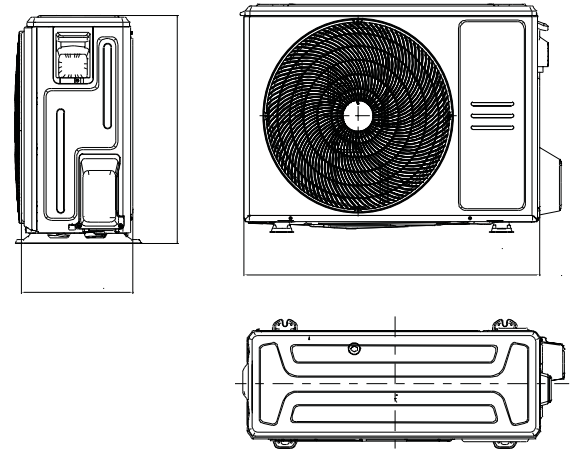

INSTALLATION

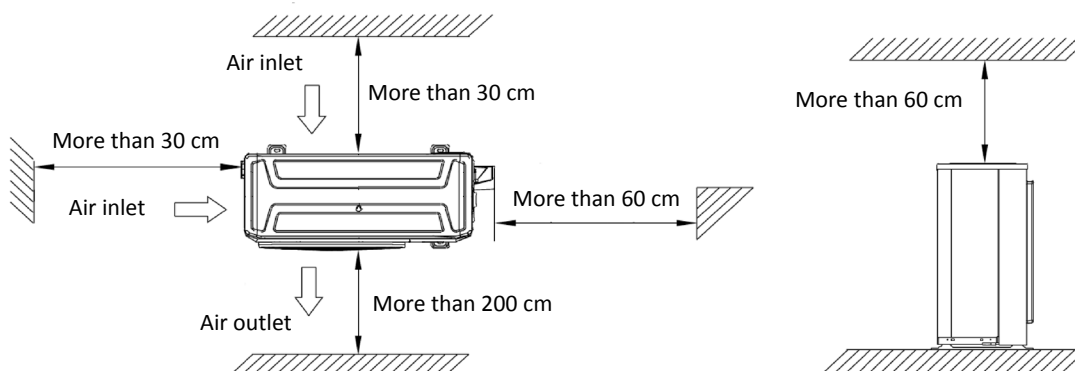

Compact Cassette 600x600

PRODUCT SHEET



KID-06 S
Recommended controller

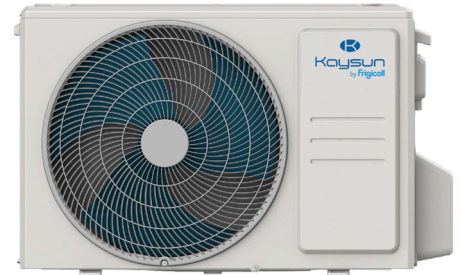

Product certified by:



FEATURES

Model	KCIA-35 DVR15
Cooling capacity	3,52 kW
Cooling power input	1.015 W
Heating capacity	3,81 kW
Heating power input	1.020 W
ErP Classification cold/heat	A++ / A+
Airflow (indoor)	330 / 520 / 620 m ³ /h
Sound pressure (indoor)	25,5 / 31,5 / 38,5 / 42 dB(A)
Airflow (outdoor)	2.000 m ³ /h
Sound pressure (outdoor)	54 dB(A)
Power supply	220-240 V / 1 / 50 Hz
Max. input	9 A
Power wiring (indoor)	With communication
Power wiring (outdoor)	(2+T)x1,50 mm ²
Communication wiring	(3+T)x1 mm ²

WIRING DIAGRAM

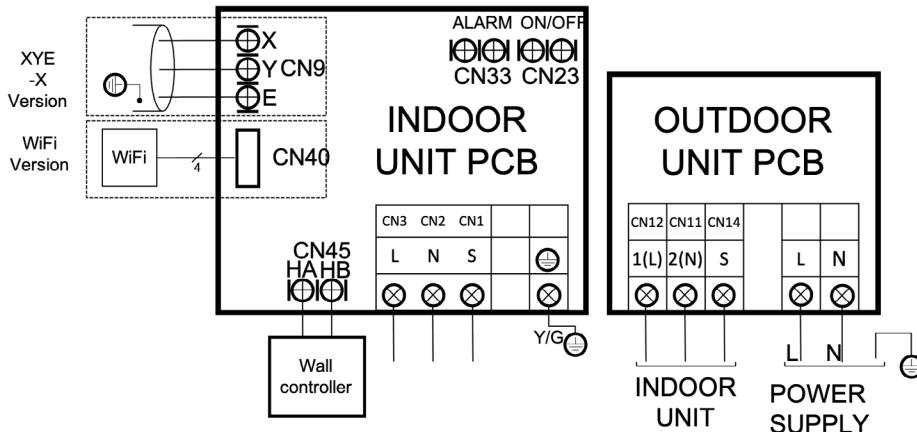

NOTES:

(1) The data and specifications present in this sheet may vary without notice.

(2) The images on this sheet are indicative and may be different from the final machine.



COOLING CONNECTION

Model	KCIA-35 DVR15	
Refrigerating pipes	Ø1/4" / Ø3/8"	
Refrigerant charge / Additional charge	0,71 kg / 0,012 kg	
Indoor drain pipe	Ø25	
Max. pipe length (A)	25 m	
Max. level difference (B)	10 m	

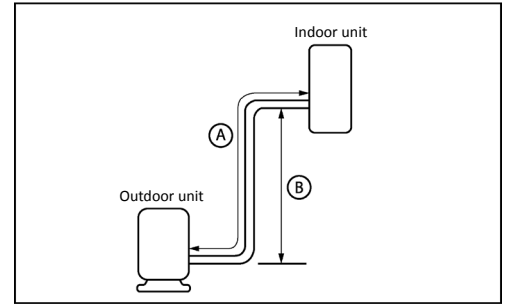

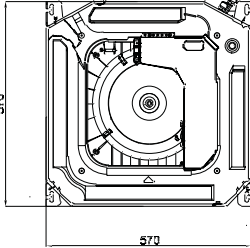
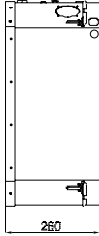

DIMENSIONS & WEIGHT INDOOR

Model	KCI-35 DR15	
		
Weight	16,20 kg	

DIMENSIONS & WEIGHT OUTDOOR

Model	KUE-35 DVR13	
Width	765 mm	
Height	555 mm	
Depth	303 mm	
Weight	26,60 kg	

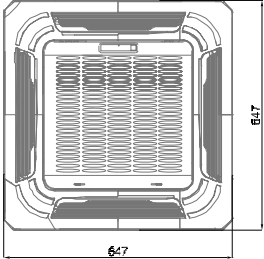
DIMENSIONS & WEIGHT PANEL

Model	KPA-03B 600x600	
		
Weight	2,70 kg	

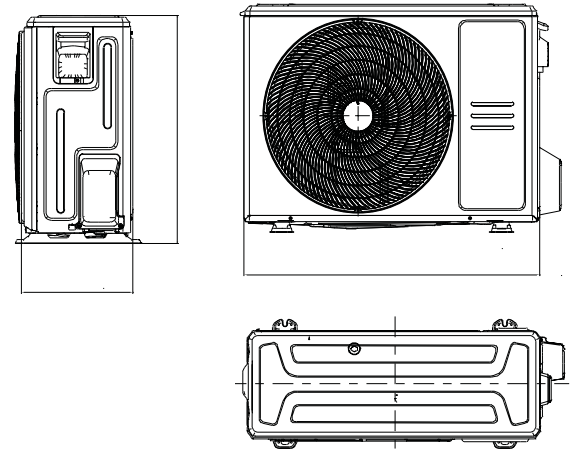

INSTALLATION

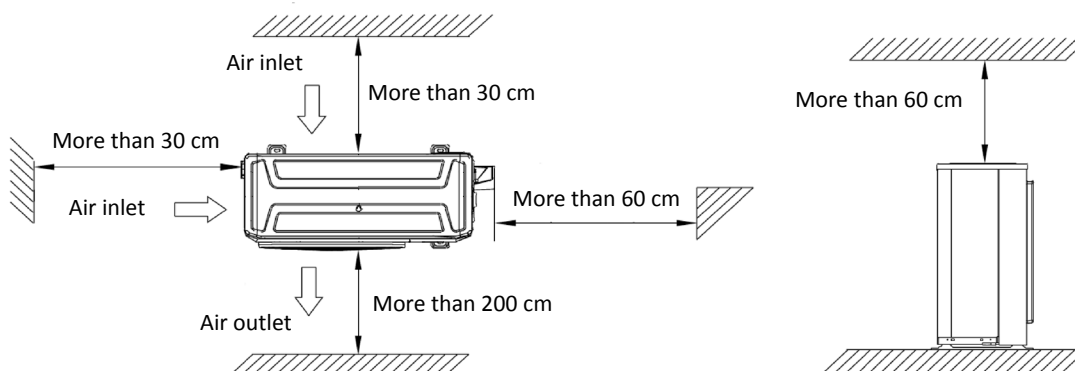

Compact Cassette 600x600

PRODUCT SHEET



KID-06 S
Recommended controller

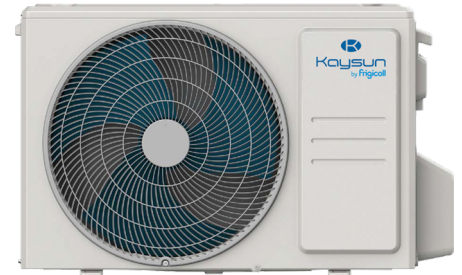

Product certified by:



FEATURES

Model	KCIA-52 DVR15
Cooling capacity	5,28 kW
Cooling power input	1.550 W
Heating capacity	5,57 kW
Heating power input	1.560 W
ErP Classification cold/heat	A++ / A+
Airflow (indoor)	300 / 540 / 660 m ³ /h
Sound pressure (indoor)	25 / 31,5 / 41 / 44 dB(A)
Airflow (outdoor)	2.100 m ³ /h
Sound pressure (outdoor)	59 dB(A)
Power supply	220-240 V / 1 / 50 Hz
Max. input	13,50 A
Power wiring (indoor)	With communication
Power wiring (outdoor)	(2+T)x1,50 mm ²
Communication wiring	(3+T)x1 mm ²

WIRING DIAGRAM

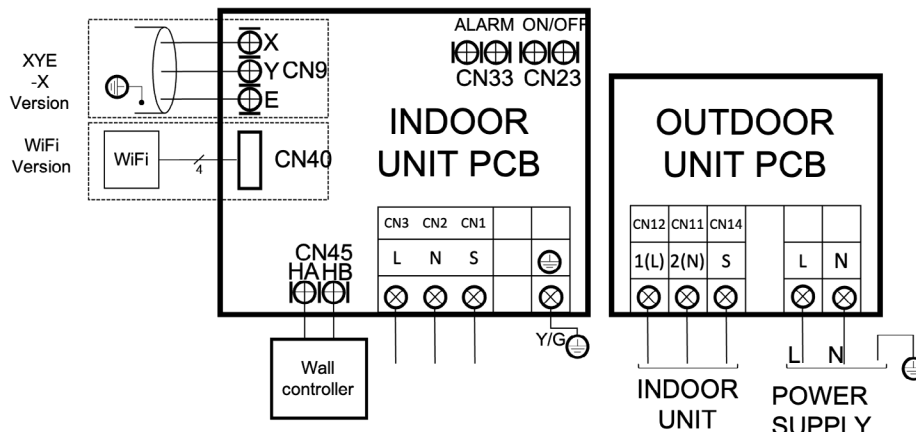

NOTES:

(1) The data and specifications present in this sheet may vary without notice.

(2) The images on this sheet are indicative and may be different from the final machine.



COOLING CONNECTION

Model	KCIA-52 DVR15	
Refrigerating pipes	Ø1/4" / Ø1/2"	
Refrigerant charge / Additional charge	1,15 kg / 0,012 kg	
Indoor drain pipe	Ø25	
Max. pipe length (A)	25 m	
Max. level difference (B)	10 m	

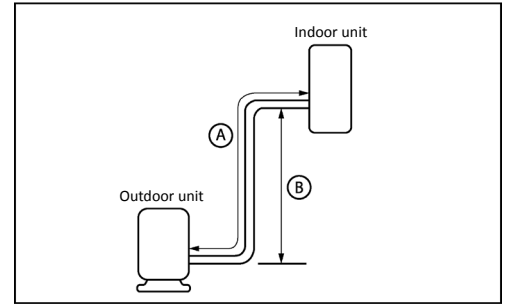

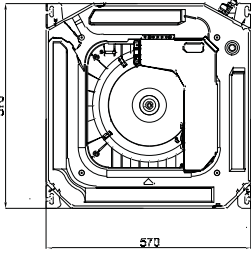
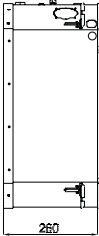

DIMENSIONS & WEIGHT INDOOR

Model	KCI-52 DR15	
		
Weight	16,20 kg	

DIMENSIONS & WEIGHT OUTDOOR

Model	KUE-52 DVR13	
Width	805 mm	
Height	554 mm	
Depth	303 mm	
Weight	32,50 kg	

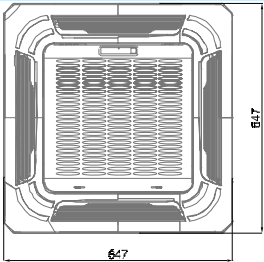
DIMENSIONS & WEIGHT PANEL

Model	KPA-03B 600x600	
		
Weight	2,70 kg	

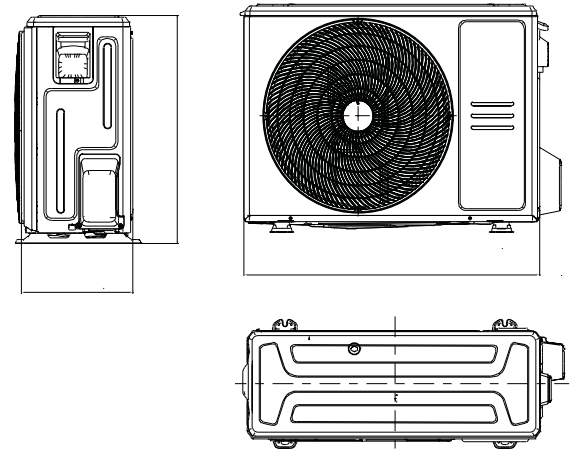

INSTALLATION

