



PARTS DRAWING

MCE MASTER
CLIMATE SOLUTIONS

**Master Dual Voltage
Propane Heater 100,000 Btu**

**Product Code:
BLP33**



Serial Number Range:

From:

To:

Year Of Manufacture: 2012

***Please note, when ordering online via our website if the part number is not recognised,
please Email spares@hscgroupuk.co.uk or Telephone 0115 946 1988**

KEEP THIS BOOKLET FOR FUTURE REFERENCE

Nottingham: 0115 946 1988 • London: 0208 830 3333 ✉ Nottingham: sales@hscgroupuk.co.uk • London: sean@hscgroupuk.co.uk 🌐 www.hscgroupuk.co.uk

The Hire Supply Company Terms & Conditions Apply At All Time E&OE

BLP 33 M DV (DUAL VOLTAGE) MODEL 2012

UNIT 1

ILLUSTRATED PARTS BREAKDOWN

Edizione 2012
Rev. A

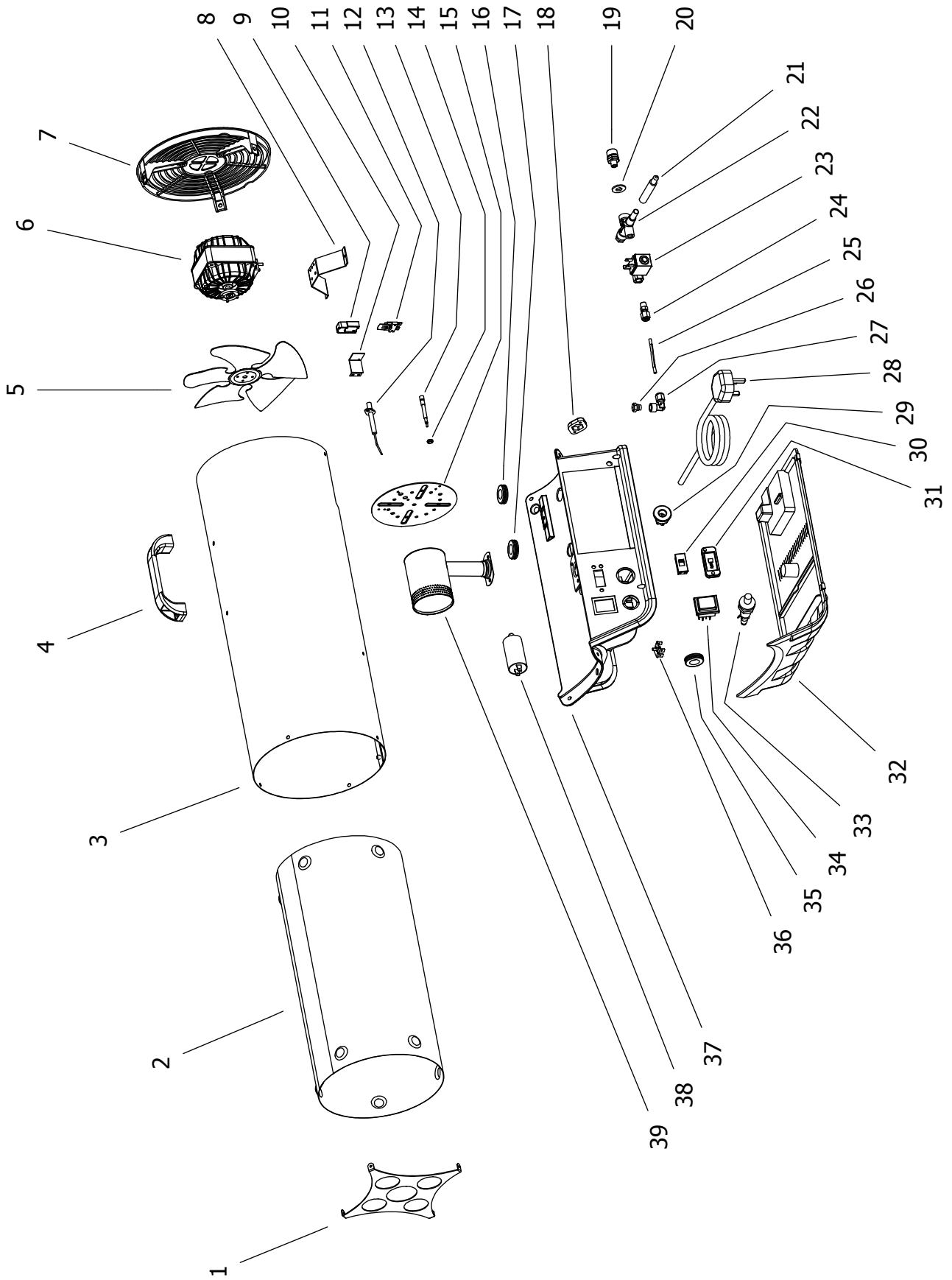

Pos.	Code NR	Description
1	4160.764	OUTLET GRID
2	4161.373	COMBUSTION CHAMBER
3	4162.890	COVER
4	4162.893	PLASTIC HANDLE
5	4161.175	FAN
6	4161.165	MOTOR
7	4161.863	PLASTIC INLET GRID
8	4161.177	MOTOR BRACKET
9	4162.909	SAFETY THERMOSTAT COVER
10	4106.047	SUPPORT FOR THERMOSTAT
11	4162.910	SAFETY THERMOSTAT
12	4160.731	IGNITION ELECTRICAL FOLDER
13	4106.041	INTERRUPTED THERMOCOUPLE
14	4106.043	THERMOCOUPLE NUT
15	4160.726	BURNER PLATE
16	4160.646	GROMMET
17	4160.646	GROMMET
18	4161.854	BLOCK FOR NOZZLE
19	4160.048	GAS INLET NOZZLE
20	4160.283	WASHER
21	4162.885	VALVE ROD
22	4161.137	SAFETY VALVE
23	4160.583	ELECTROVALVE
24	4160.623	NIPPLES REDUCER
25	4162.886	COPPER TUBE
26	4162.887	GAS NOZZLE
27	4160.621	ELBOW
28	4160.540	POWER CORD
29	4160.635	KEEPER WIRE
30	4160.117	SWITCH DUAL VOLTAGE
31	4161.284	SWITCH COVER
32	4162.883	LOWER PLASTIC BASE
33	4162.222	PIEZO IGNITOR
34	4160.637	SWITCH
35	4160.646	GROMMET
36	4160.639	RIVET POP
37	4162.734	UPPER PLASTIC BASE
38	4161.830	CAPACITOR 2 μ F
39	4162.659	GAS BURNER



Recycling



ENVIRONMENTAL PROTECTION: Please recycle any unwanted materials as opposed to disposing them as general waste. It is recommended the original is retained and used to store the product when not in use for prolonged periods of time. If this is not applicable ensure the materials are sorted and recycled in accordance with local regulations.



SPECIFICATION CHANGE: It is our policy to continually improve products to ensure these meet the rigours of the industry we serve. Therefore, as such we reserve the right to alter specifications, data, components & parts with-out prior notice.

WARRANTY: Please refer to the manufactures terms & conditions.

IMPORTANT: No liability will be accepted for the incorrect use of this product.

KEEP THIS BOOKLET FOR FUTURE REFERENCE

📞 Nottingham: 0115 946 1988 • London: 0208 830 3333 ✉ Nottingham: sales@hscgroupuk.co.uk • London: sean@hscgroupuk.co.uk 🌐 www.hscgroupuk.co.uk

The Hire Supply Company Terms & Conditions Apply At All Time E&OE