

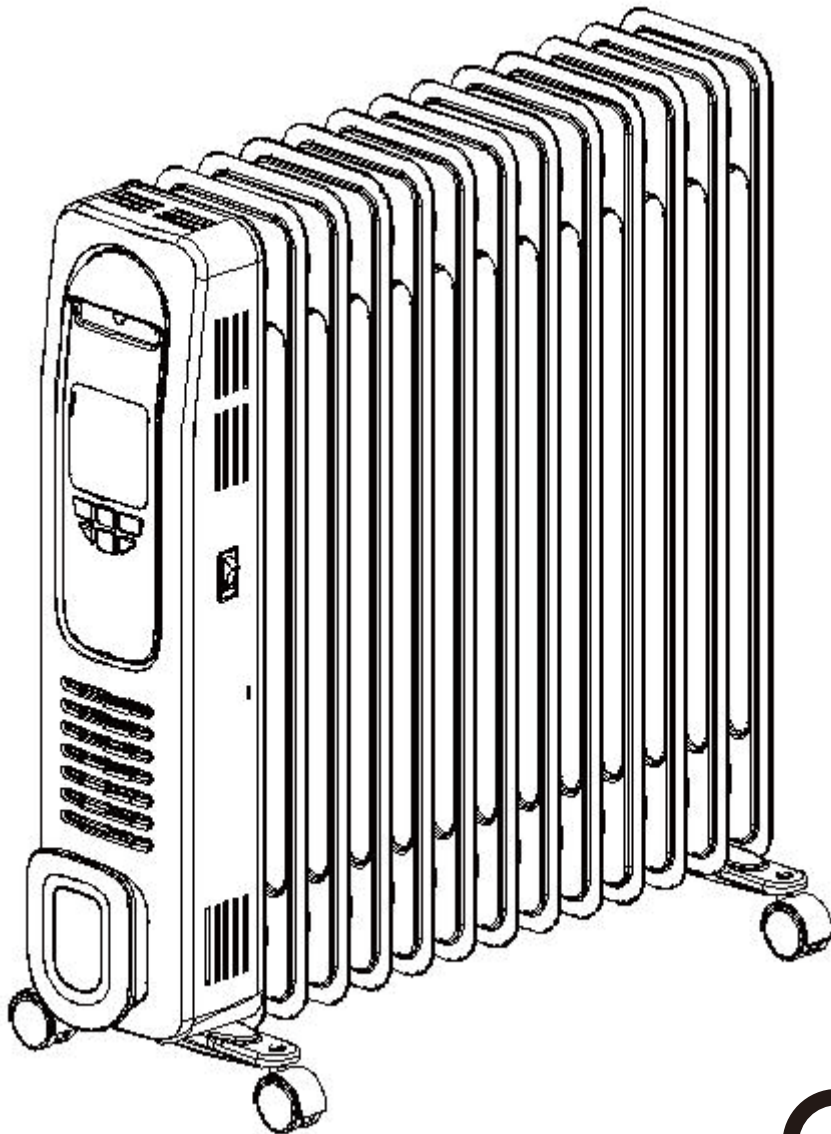

IN221000528V02\_UK

**820-276\_820-267\_820-265V70**

## Electric Oil Heater Instructions



IMPORTANT, RETAIN FOR FUTURE REFERENCE: READ CAREFULLY

# ASSEMBLY & INSTRUCTION MANUAL

# INSTRUCTIONS

Thank you for choosing our oil heater, please read the instruction carefully before use and save it for future reference

## Product Characteristic

◆ The electric oil heater manufactured by our company uses tubular elements as the heat source, high-efficiency permanent heat-conducting oil as the medium, dissipates heat through the heat sink, and uses air circulation to increase the room temperature.

◆ The electric heating oil heater has the characteristics of convenient use, safety, beautiful appearance, quiet operation and no electromagnetic interference. It is suitable for scientific research, hospitals, hotels, exercise rooms, bedrooms and other places. It makes your room or office more warm and comfortable in the cold season.

## Product Structure

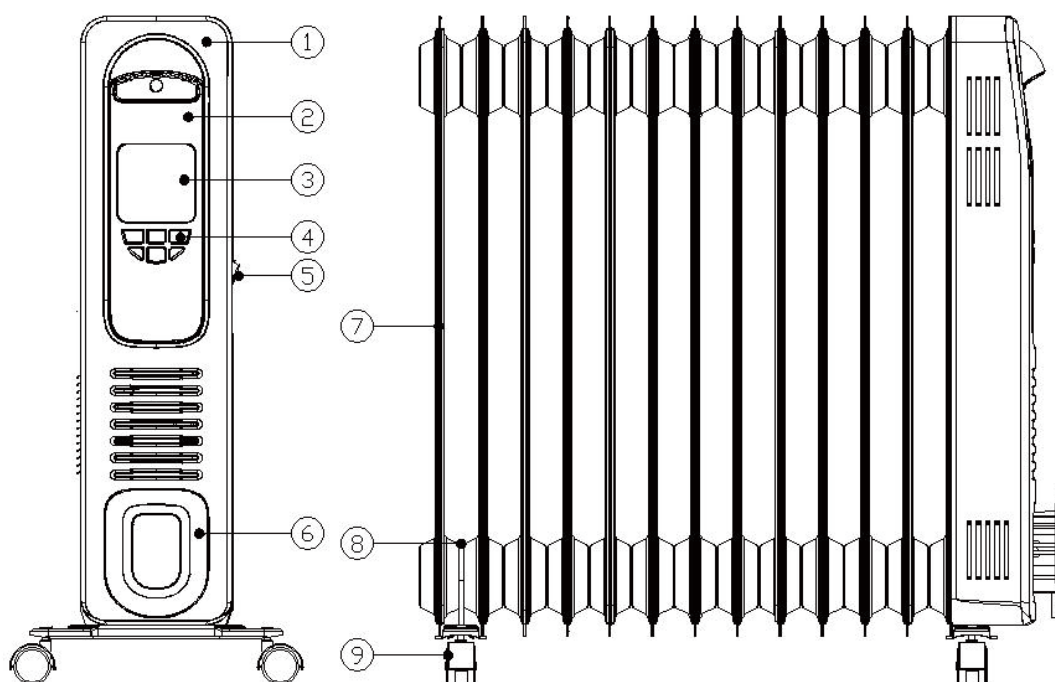

Figure1ProductStructure

1.ControlBox

4.Button

7.Body

2.ControlPanel

5.ON-OFFSwitch

8.UScrew

3.Displaypanel

6.CordStorage

9.Castor

# INSTRUCTIONS FOR USE

## INSTALLATION METHOD:

(1)Remove the heater and all parts from the packaging box.

(2)Turn the heater upside down, position the castor board between the end fins. Attach them to the U-bolts on the heater and tighten using the wing nuts provided., shown in Figure 2;

(3)Turn heater right-side up.

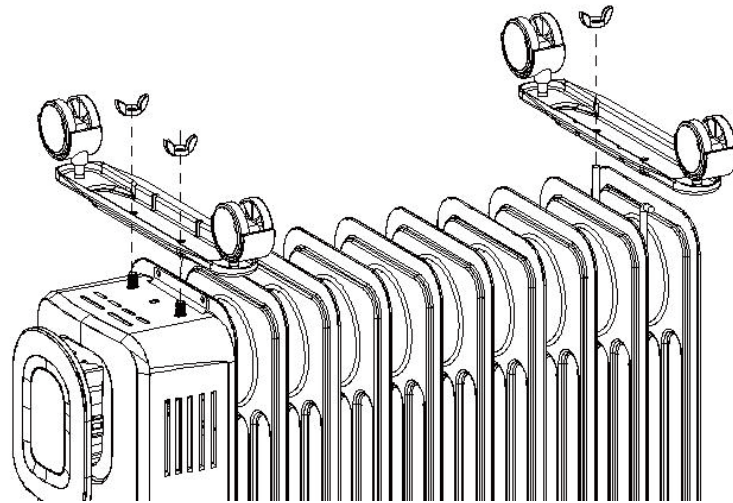

Figure 2

Castor Board Installation Diagram

**1.CHECK BEFORE START :**

- (1)Power line should not be damaged, fracture phenomena;
- (2) Please make sure the parameters required by your power and heater nameplate before use make sure that the power outlet current rating meets the requirements and has a safety ground, or should replace the outlet.

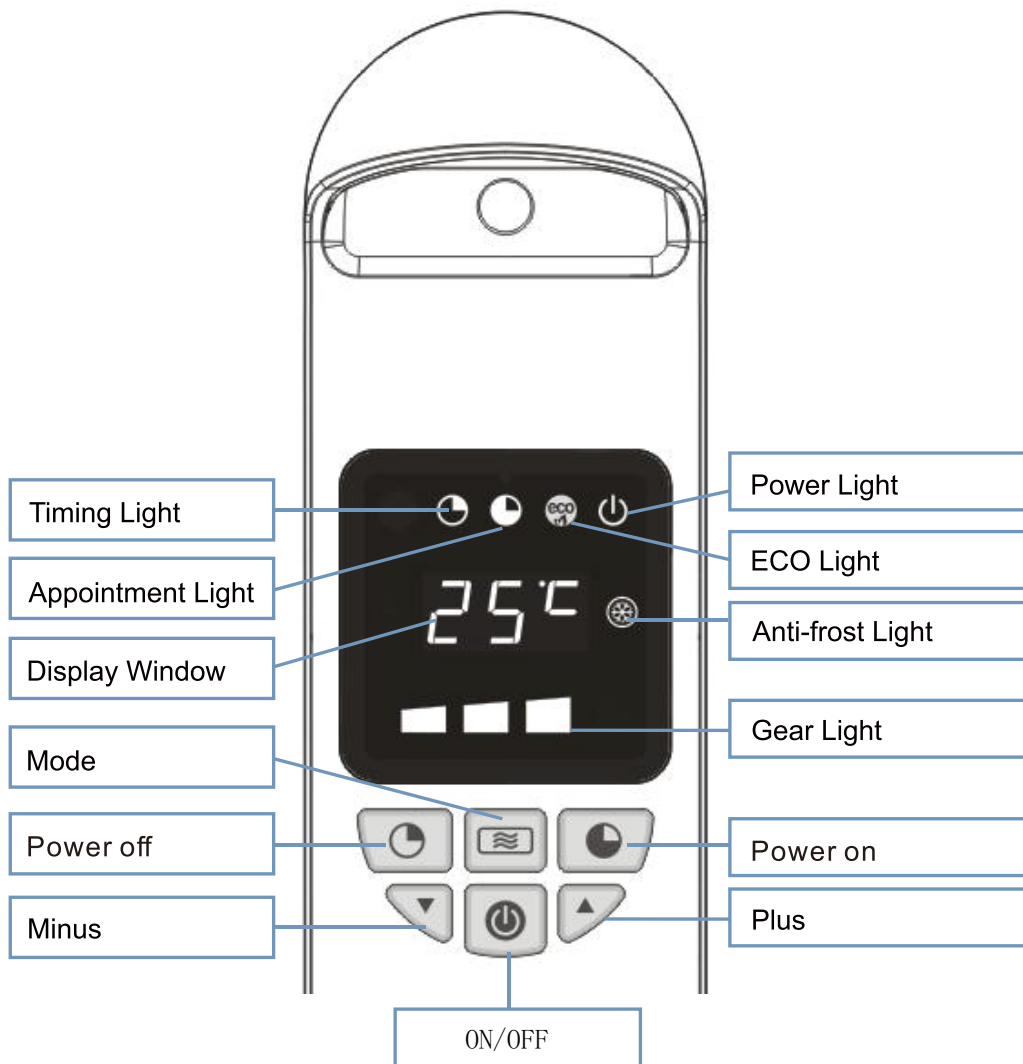

Figure 3

A Schematic View of The Control panel

**1.Plug in the power cord and turn on the main mechanical switch: the power icon light is on and the product goes into standby**

**2.ON/OFF:**

It acts as a switch. After shutdown, the machine remembers the state before shutdown without power off (timer function does not remember)

**3、 ▲/▼ :**

3.1 In the power-on state, and the timing setting operation is not performed, you can press "▲" and "▼" to select the set temperature. The setting range is 7-35 ℃; the default temperature is 24 ℃;

3.2 When the machine is in the timing setting state, you can press "▲" and "▼" to select the timing time, the maximum setting is 24h, zero is no timing;

3.3 In the power-on state, press and hold "▲" and "▼" simultaneously for 5 seconds to turn on the conversion between the Celsius mode (point + c) and Fahrenheit mode (point + F).

3.4 In Fahrenheit mode, the default temperature is 75 ° F and the setting range is 45-95 ° F

3.5 The Celsius and Fahrenheit modes have a memory function, and the last mode can still be remembered after a complete power failure.

**4、 Appointment/Timer:**

Press the reservation (or timer) button to enter the corresponding time setting, the reservation lamp (or timer lamp) flashes, adjust the time by adding and subtracting keys, automatically confirm after 5 seconds of no operation (maximum setting 24h, 0h is no timer) or directly press Confirm with the reservation button (or timer button). After confirmation, the reservation lamp (or timing lamp) will be on continuously. You can set the scheduled power-on and scheduled power-off at the same time, regardless of the set time, always follow the principle of first confirmation and first execution;

**5、 Mode:**

5.1 In the power-on state, press this key to switch the heating mode of the machine. The default Hi file is the first time the power is turned on, and the switching sequence is Hi → Med → Low → ECO→ Hi →... cycle.

**6、 Function of tipping:**

6.1 When the angle between the machine dumping and the horizontal position is less than 30 ± 5 degrees, the digital tube flashes to prompt "Eo", and all outputs are turned off;

6.2 When the angle between the machine's centering and the horizontal position is greater than 70 ± 5 degrees, the working state before dumping will be restored.

**7、 Function of Anti-frost**

7.1 In the standby state, the mid-range heating is automatically turned on when the NTC temperature is lower than 5 ℃ (41 °F), and when the NTC temperature is higher than 7 ℃ (45 °F), the heating is stopped and returned to the standby state.

7.2 When the frost protection function is turned on, the ON/STANDBY key become highlight and flashes at a frequency of 2 seconds per time, and the display window shows the room temperature (degrees Celsius or Fahrenheit).

**SUPPLEMENTARY EXPLANATION:**

1. When the machine is in the reservation state, it is not displayed except for the reservation mark and time content. If you press the "mode" key, the corresponding mode is displayed. At this time, you can use the mode key or ▲ / ▼ key to select the mode. If there is no such operation for 5 seconds, the mode icon will go out again. If you press the "▲" and "▼" keys, the set temperature content flashes. At this time, you can continue to press the ▲ / ▼ key to adjust, and it will go out again after 5 seconds of no operation;
2. The machine in working state has no operation after 3 minutes of operation, and automatically enters the state of extinguishing the screen; pressing any button in the state of extinguishing the screen can wake up the body. The machine in the reservation state does not enter the screen off, the reservation icon is always on, and the digital tube is always on to show the remaining time of the reservation.
3. If the sensor is short-circuited, it will flash "EH"; if the sensor is open, it will flash "EL".
4. The temperature control method is as follows:

T = set temperature (7 ~ 35 °C), t = ambient temperature

When the machine works in ECO mode

TEMPUP		TEMPDOWN	
t < T	Hi	t > T+1	OFF
t = T	Hi	T < t ≤ T+1	Mid
T < t ≤ T+1	Mid	t = T	Mid
t > T+1	OFF	t < T	Hi

When the machine works in one of Hi, Mid and Lo modes

TEMPUP		TEMPDOWN	
t < T	Hi/Med/Low	t ≥ T+1	OFF
t = T	Hi/Med/Low	t = T	OFF
t ≥ T+1	OFF	t < T	Hi/Med/Low

**CLEANING AND MAINTENANCE**

- (1) Avoid scratching or scratching the heater to avoid rust due to damage to the surface coating.
- (2) When not in use for a long time, clean the electric heater with a soft cloth and store it in the packing box.

## **IMPORTANT NOTES**

1. Read all instructions before using the heater.
2. To prevent overheating, Do not cover the heater.
3. The heater can not be located immediately below an electrical outlet or electrical outlet.
4. The heater is not suitable in humid environments, such as bathrooms and water or to the place susceptible to washout, and should prevent water droplets from entering or splashing into the control box. Do not have more flammable and explosive gases in the environment to use the heater.
5. If the power cord is damaged, in order to avoid danger, it must be made by the manufacturer, its service agent or similarly qualified professionals with certain sectors of the same type to replace the original power cord.
6. The heater should be filled with a precise amount of professional HTF. Asked to open the fins must be repaired only by the manufacturer or service personnel to carry out, if the oil leak, also must contact them to deal with.
7. Scrapped heater, please comply with the relevant provisions of the oil processed.
8. When using the heater should be placed on a smooth, you can not turn or tilt use.
9. Do not put clothes and towels and other items directly on the heater baking.
10. After use or when unattended, please turn off and unplug it. It is forbidden to turn off or turn on the device by pulling or plugging in the plug.
11. Clean heater, turn it off and unplug it, and stand body to cool before cleaning.
12. When the heater work, please do not let the power cord contact with the body.
13. Unusual circumstances such as the heater does not work, please turn off the heater immediately and sent to the nearest designated repair point for a professional inspection, repair, and replacement parts are not allowed to disassemble.
14. Do not use electric heaters and other appliances in the same outlet or the same circuit, so as not to cause too much load circuit overload or even cause a fire.
15. Prohibited the use of an extension cord.
16. Prohibited the use of automatic power program, timer or any other device to use the heater.
17. Do not put hands, sticks and other objects inserted into the apertures of the heater, to prevent accidents.
18. When using the heater, in order to avoid burns, do not let bare skin in direct contact with electric heating the surface. Be sure to take advantage of when you need to move in front of the handle.
19. Do not have towels, clothing, bed sheets, bedding, curtains and other combustible materials within the heater around 1 meter Products, and should be kept away after thermal deformation or discoloration of furniture and other items.
20. There shall be no obstructions or unstable hanging objects within 1 meter from the top of the heater.
21. When using the heater, to watch over the child, do not let the child feel free to touch the heater, in order to avoid unnecessary damage.

22. When using the heater, do not frequent switching windows and doors, it will affect the heating effect.

23. Do not use the heater outdoors.

24. Keep the product specification, not discarded.

Only for UK:

A. Do not use two high-power appliances in the same socket

B. The plug needs to be plugged in fully

C. Product socket cannot use extension cord.

The socket need to be conformed to BS1363, The maximum withstand current value needs to be greater than 13A.

### Electrical schematic diagram

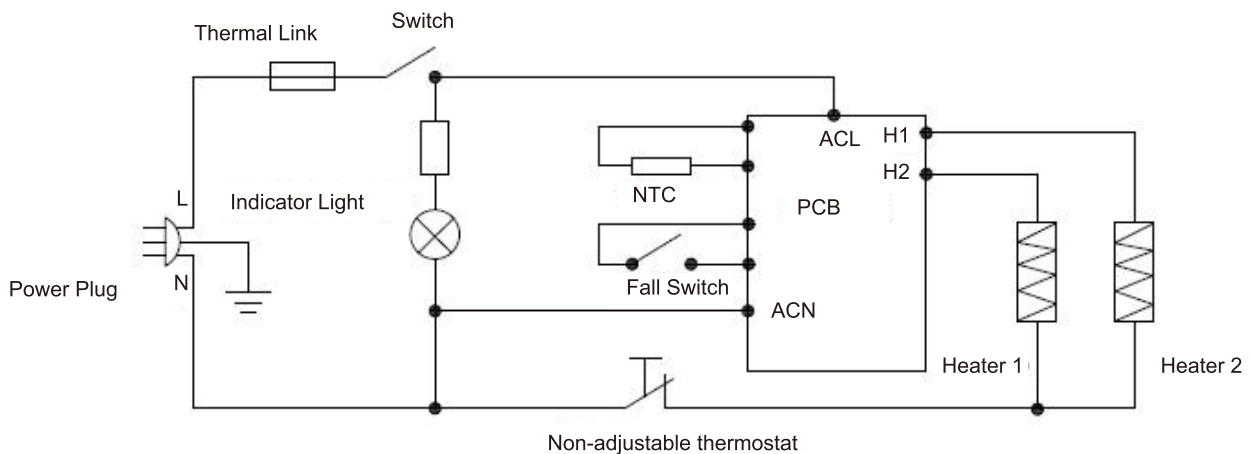

Figure 5  
Product Electrical Schematic Diagram

### Main technical parameters

Model	Number offins	Rated voltage(V)	Rate (Hz)	power(W)	Note
HD972E-A5Q	5	220-240	50/60	910-1100	
HD972E-A7Q	7	220-240	50/60	1370-1630	
HD972E-A9Q	9	220-240	50/60	1830-2180	
HD972E-A11LQ	11	220-240	50/60	2000-2400	
HD972E-A11Q	11	220-240	50/60	2290-2720	
HD972E-A13Q	13	220-240	50/60	2290-2720	
HD972E-A15Q	15	220-240	50/60	2380-2830	

If you have any questions, please contact our customer care center.

Our contact details are below:



0044-800-240-4004



enquiries@mhstar.co.uk

IMPORTER ADDRESS:  
MH STAR UK LTD  
Unit 27, Perivale Park,  
Horsenden lane South  
Perivale, UB6 7RH  
MADE IN CHINA

